



---

Quasar™

# Installation and User Guide

## 4K IR PTZ Cameras

---



22x CP-6408-21-I



31x CP-6408-31-I

---

© 2021 FLIR Systems, Inc. All rights reserved worldwide. No parts of this manual, in whole or in part, may be copied, photocopied, translated, or transmitted to any electronic medium or machine readable form without the prior written permission of FLIR Systems, Inc..

Names and marks appearing on the products herein are either registered trademarks or trademarks of FLIR Systems, Inc. and/or its subsidiaries. All other trademarks, trade names, or company names referenced herein are used for identification only and are the property of their respective owners.

This product is protected by patents, design patents, patents pending, or design patents pending.

Photographs and images appearing in this manual may have been modified for illustrative purposes using commercial image editing software and may not always reflect an actual product configuration.

The contents of this document are subject to change without notice.

For additional information visit [www.flir.com](http://www.flir.com) or write to FLIR Systems, Inc.

FLIR Systems, Inc.  
6769 Hollister Avenue  
Goleta, CA 93117

Support: <https://support.flir.com/>

### Important Instructions and Notices to the User:

This device complies with part 15 of the FCC Rules. Operation is subject to the following two conditions: (1) This device may not cause harmful interference, and (2) this device must accept any interference received, including interference that may cause undesired operation.

Modification of this device without the express authorization of FLIR Systems, Inc. may void the user's authority under FCC rules to operate this device.

**Note 1:** This equipment has been tested and found to comply with the limits for a Class A digital device, pursuant to part 15 of the FCC Rules. These limits are designed to provide reasonable protection against harmful interference when the equipment is operated in a commercial environment. This equipment generates, uses, and can radiate radio frequency energy and, if not installed and used in accordance with the instruction manual, may cause harmful interference to radio communications. Operation of this equipment in a residential area is likely to cause harmful interference in which case the user will be required to correct the interference at the user's own expense.

**Note 2:** If this equipment came with shielded cables, it was tested for compliance with the FCC limits for a Class A digital device using shielded cables and therefore shielded cables must be used with the device.

### Industry Canada Notice:

This Class A digital apparatus complies with Canadian ICES-003.

### Avis d'Industrie Canada:

Cet appareil numérique de la classe A est conforme à la norme NMB-003 du Canada.

### Proper Disposal of Electrical and Electronic Equipment (EEE)



The European Union (EU) has enacted Waste Electrical and Electronic Equipment Directive 2012/19/EU (WEEE), which aims to prevent EEE waste from arising; to encourage reuse, recycling, and recovery of EEE waste; and to promote environmental responsibility.

In accordance with these regulations, all EEE products labeled with the "crossed out wheeled bin" either on the product itself or in the product literature must not be disposed of in regular rubbish bins, mixed with regular household or other commercial waste, or by other regular municipal waste collection means. Instead, and in order to prevent possible harm to the environment or human health, all EEE products (including any cables that came with the product) should be

### Document History

Revision	Date	Comment
100	February 2020	v1.6.0.16 - Initial FLIR release of CP-6408-21-I camera
110	June 2020	Added Class 1 Laser Product compliance-related content
120	September 2020	v1.6.0.31 - Initial FLIR release of CP-6408-31-I camera
130	May 2021	Added pendant cap thread specification; updated FLIR Support contact information

# Product Registration and Warranty Information

---

Register your Product with FLIR at <https://customer.flir.com>.

For warranty information, see <https://www.flir.com/support-center/warranty/security/flir-security-product-warranties/>.

# Table of Contents

---

<b>1. Document Scope and Purpose</b>	<b>1</b>
<b>2. Camera Overview</b>	<b>4</b>
2.1 Accessing Product Information from the FLIR Website	5
2.2 Camera Dimensions	6
<b>3. Installation</b>	<b>8</b>
3.1 Supplied Components	8
3.2 Site Preparation	9
3.3 Camera Connections	10
3.4 Supplying Power to the Camera	11
3.5 Waterproofing the Camera	13
3.6 Mounting the Camera	13
3.6.1 Securing the Camera	13
3.6.2 Wall Mount Bracket CX-ARMX-G3	15
3.6.3 Wall Mount Bracket with Power Box CX-ELBX-G3	16
3.6.4 Gooseneck Mount with Power Box CX-GSNK-G3	18
3.6.5 Mount Adapters	19
3.6.5.1 Corner Adapter CX-CRNR-G3	19
3.6.5.2 Pole Adapter CX-POLE-G3	21
3.7 Initial Configuration	22
3.7.1 Configure for Networking	22
3.7.2 Change Video Format (Optional)	24
3.7.3 Install and Test the Optional Wash Kit	24
3.7.4 Attach the Camera to a VMS	27
<b>4. Operation</b>	<b>28</b>
4.1 Accessing the Camera	28
4.2 View Settings Home Page	28
4.3 Video Page	30
4.4 Visible Page	32
4.5 Input/Output (I/O) Page	36
4.6 PTZ Page	37
4.7 Illumination Page	39
4.8 OSD Page	39
4.9 Wiper Page	39
4.10 Georeference Page	40
<b>5. Configuration</b>	<b>42</b>
5.1 Network Page	42



# Table of Contents

---

- 5.2 Date & Time Page ..... 43
- 5.3 Users Page ..... 44
- 5.4 Cloud Page ..... 45
- 5.5 Audio Page ..... 46
- 5.6 I/O Devices Page ..... 46
- 5.7 Cyber Page ..... 48
  - 5.7.1 Certificates ..... 48
  - 5.7.2 802.1x ..... 49
  - 5.7.3 TLS/HTTPS ..... 50
  - 5.7.4 Services ..... 50
- 5.8 ONVIF Page ..... 51
- 5.9 Firmware & Info Page ..... 52
- 6. Maintenance and Troubleshooting Tips ..... 54**
  - 6.1 Cleaning ..... 54
  - 6.2 Troubleshooting ..... 54

# 1 Document Scope and Purpose

The purpose of this document is to provide installation, operation, and configuration instructions for Quasar CP-6408 cameras.



## Note:

This document is intended for use by technical users who have a basic understanding of CCTV camera/video equipment and LAN/WAN network connections.

## Remarque:

*Ce document est destiné aux utilisateurs techniciens qui possèdent des connaissances de base des équipements vidéo/caméras de télésurveillance et des connexions aux réseaux LAN/WAN.*

## Disclaimer

Users of FLIR products accept full responsibility for ensuring the suitability and considering the role of the product detection capabilities and their limitation as they apply to their unique site requirements.

FLIR Systems, Inc. and its agents make no guarantees or warranties to the suitability for the users' intended use. FLIR Systems, Inc. accepts no responsibility for improper use or incomplete security and safety measures.

Failure in part or in whole of the installer, owner, or user in any way to follow the prescribed procedures or to heed WARNINGS and CAUTIONS shall absolve FLIR and its agents from any resulting liability.

Specifications and information in this guide are subject to change without notice.

## Avis de non-responsabilité

*Il incombe aux utilisateurs des produits FLIR de vérifier que ces produits sont adaptés et d'étudier le rôle des capacités et limites de détection du produit appliqués aux exigences uniques de leur site.*

*FLIR Systems, Inc. et ses agents ne garantissent d'aucune façon que les produits sont adaptés à l'usage auquel l'utilisateur les destine. FLIR Systems, Inc. ne pourra être tenu pour responsable en cas de mauvaise utilisation ou de mise en place de mesures de sécurité insuffisantes.*

*Le non respect de tout ou partie des procédures recommandées ou des messages d'AVERTISSEMENT ou d'ATTENTION de la part de l'installateur, du propriétaire ou de l'utilisateur dégagera FLIR Systems, Inc. et ses agents de toute responsabilité en résultant.*

*Les spécifications et informations contenues dans ce guide sont sujettes à modification sans préavis.*



A **Warning** is a precautionary message that indicates a procedure or condition where there are potential hazards of personal injury or death.

**Avertissement** est un message préventif indiquant qu'une procédure ou condition présente un risque potentiel de blessure ou de mort.



A **Caution** is a precautionary message that indicates a procedure or condition where there are potential hazards of permanent damage to the equipment and or loss of data.

***Attention** est un message préventif indiquant qu'une procédure ou condition présente un risque potentiel de dommages permanents pour l'équipement et/ou de perte de données.*



A **Note** is useful information to prevent problems, help with successful installation, or to provide additional understanding of the products and installation.

*Une **Remarque** est une information utile permettant d'éviter certains problèmes, d'effectuer une installation correcte ou de mieux comprendre les produits et l'installation.*



A **Tip** is information and best practices that are useful or provide some benefit for installation and use of FLIR products.

*Un **Conseil** correspond à une information et aux bonnes pratiques utiles ou apportant un avantage supplémentaire pour l'installation et l'utilisation des produits FLIR.*

## General Cautions and Warnings

This section contains information that indicates a procedure or condition where there are potential hazards.

### **SAVE ALL SAFETY AND OPERATING INSTRUCTIONS FOR FUTURE USE.**

Although the unit is designed and manufactured in compliance with all applicable safety standards, certain hazards are present during the installation of this equipment.

To help ensure safety and to help reduce risk of injury or damage, observe the following:

## Précautions et avertissements d'ordre général

Cette section contient des informations indiquant qu'une procédure ou condition présente des risques potentiels.

### **CONSERVEZ TOUTES LES INSTRUCTIONS DE SÉCURITÉ ET D'UTILISATION POUR POUVOIR VOUS Y RÉFÉRER ULTÉRIEUREMENT.**

Bien que l'unité soit conçue et fabriquée conformément à toutes les normes de sécurité en vigueur, l'installation de cet équipement présente certains risques.

Afin de garantir la sécurité et de réduire les risques de blessure ou de dommages, veuillez respecter les consignes suivantes:



**Warning:**

- Installation must follow safety, standards, and electrical codes as well as the laws that apply where the units are being installed.
- The unit's cover is an essential part of the product. Do not open or remove it.
- Never operate the unit without the cover in place. Operating the unit without the cover poses a risk of fire and shock hazards.
- Do not disassemble the unit or remove screws. There are no user serviceable parts inside the unit.
- Only qualified trained personnel should service and repair this equipment.
- Observe local codes and laws and ensure that installation and operation are in accordance with fire, security and safety standards.

**Avertissement:**

- *L'installation doit respecter les consignes de sécurité, les normes et les codes électriques, ainsi que la législation en vigueur sur le lieu d'implantation des unités.*
- *Le cache de l'unité est une partie essentielle du produit. Ne les ouvrez et ne les retirez pas.*
- *N'utilisez jamais l'unité sans que le cache soit en place. L'utilisation de l'unité sans cache présente un risque d'incendie et de choc électrique.*
- *Ne démontez pas l'unité et ne retirez pas ses vis. Aucune pièce se trouvant à l'intérieur de l'unité ne nécessite un entretien par l'utilisateur.*
- *Seul un technicien formé et qualifié est autorisé à entretenir et à réparer cet équipement.*
- *Respectez les codes et réglementations locaux, et assurez-vous que l'installation et l'utilisation sont conformes aux normes contre l'incendie et de sécurité.*



**Warning:**

- Do not drop the camera or subject it to physical shock.
- Do not touch sensor modules with fingers. If cleaning is necessary, use a clean cloth with a bit of ethanol and wipe it gently. If the camera will not be used for an extended period of time, put on the lens cap to protect the sensor from dirt.
- Do not aim the camera lens at strong light, such as the sun or an incandescent lamp, which can seriously damage the camera.
- Make sure that the surface of the sensor is not exposed to a laser beam, which could burn out the sensor.
- If the camera will be fixed to a ceiling, verify that the ceiling can support more than 23 newtons (23-N) of gravity, or over three times the camera's weight.
- The camera should be packed in its original packing if it is reshipped.



**Caution:**

To avoid damage from overheating or unit failure, assure that there is sufficient temperature regulation to support the unit's requirements (cooling/heating). Operating temperature should be kept within the range specified by the camera's technical specifications.

**Attention:**

*Afin d'éviter tout dommage dû à une surchauffe ou toute panne de l'unité, assurez-vous que la régulation de température est suffisante pour répondre aux exigences de l'unité (refroidissement/chauffage). La température de fonctionnement doit être maintenue dans l'intervalle spécifié par les spécifications techniques de l'appareil photo.*

## 2 Camera Overview

CP-6408 cameras include a 4K visible light camera with 22x (CP-6408-21-I) or 31x (CP-6408-31-I) optical zoom; audio; digital I/O; near-infrared (NIR) illumination; and automatic side heat sensors. The CP-6408-31-I also includes laser focus technology (LiDAR) and a camera lens window wiper (wash kit available as an optional accessory). When the camera is connected to an IP network, it functions as a server, providing services such as camera control, video streaming, and network communications. The server uses an open, standards-based communication protocol to communicate with FLIR and third-party video management system (VMS) clients, including systems that are compatible with ONVIF®. These clients can be used to control the camera and stream video during day-to-day operations. For a list of supported VMS clients, refer to the product's web page on [FLIR.com](https://www.flir.com).

The video from the camera is viewed by streaming it over an IP network using MJPEG and H.264 encoding.

If help is needed during the installation process, contact the local FLIR service representative or call the support number that appears on the product's page at <https://support.flir.com/>. All installers and integrators are encouraged to take advantage of the training offered by FLIR; visit <https://www.flir.com/support-center/training/> for more information.

For safety, and to achieve the highest levels of performance from the camera system, always follow the warnings and cautions in this manual when handling and operating the camera.

**CLASS 1 LASER PRODUCT**

*These cameras are Class 1 Laser Products that comply with IEC 60825-1:2014.*



### Caution

Use of controls or adjustments or performance of procedures other than those specified herein may result in hazardous radiation exposure.

### Attention

*L'utilisation des commandes ou réglages ou l'exécution des procédures autres que celles spécifiées dans les présents exigences peuvent être la cause d'une exposition à un rayonnement dangereux.*



### Warning

Before drilling into surfaces for camera mounting, verify that electrical or other utility service lines are not present. Serious injury or death may result from failure to heed this warning.



### Caution

Except as described in this manual, do not open the camera for any reason. Damage to the camera can occur as the result of careless handling or electrostatic discharge (ESD). Always handle the camera with care to avoid damage to electrostatic-sensitive components.

Prior to making any connections, ensure the power supply or circuit breaker is switched off.

Be careful not to leave fingerprints on the camera's infrared optics.

Operating the camera outside of the specified input voltage range or the specified operating temperature range can cause permanent damage.

### Related Documentation

- *CP-6408-21-I or CP-6408-31-I Quick Install Guide*
- *FLIR CGI Interface Description 2.1*

- *Nexus CGI WebSockets Manual*
- *FLIR Sensors SDK Programmer's Guide*

## 2.1 Accessing Product Information from the FLIR Website

Up-to-date resources for the camera, including the camera's specifications, the FLIR Discovery Network Assistant (DNA) software tool, and this installation and user guide, are available from the camera's product information and support pages on [FLIR.com](https://www.flir.com). Select Products > Security > Visible Security Cameras, and then click the relevant product.

**To access product information from the FLIR website:**

1. Open <https://www.flir.com/browse/security/visible-security-cameras/>.

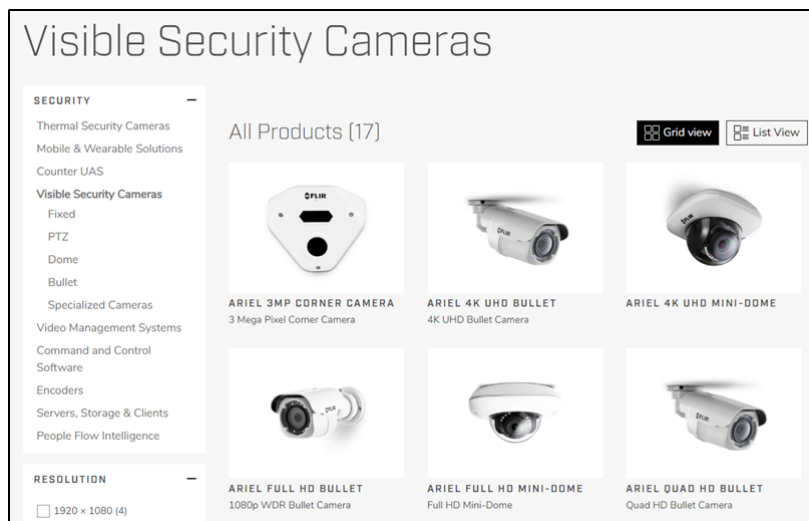

*Visible Security Cameras Page on FLIR.com*

2. Find and click the camera. The camera's product information page appears.

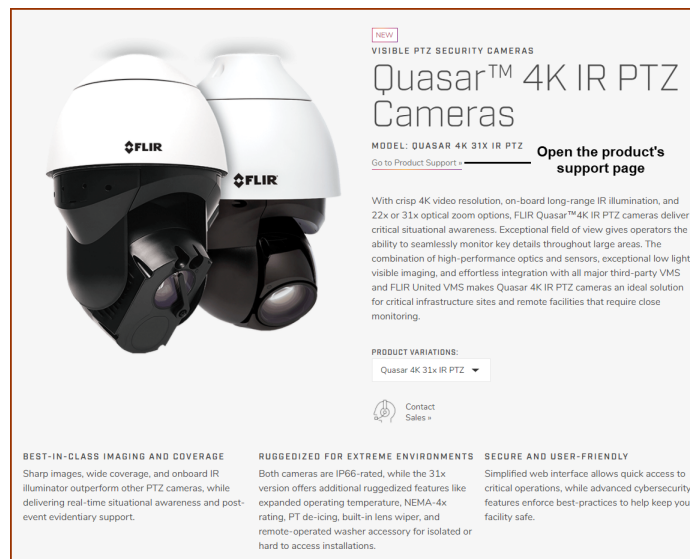

*Quasar 4K IR PTZ (CP-6408-31-I) Camera Product Information Page on FLIR.com*

3. Scroll down to see the camera's specifications and related documents.
4. Click **Go to Product Support** to open the camera's support page.

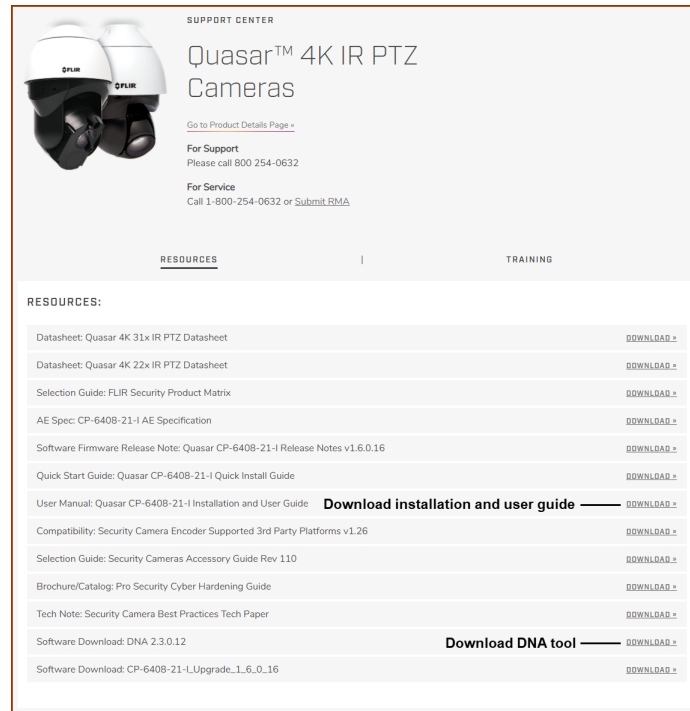

Quasar 4K IR PTZ Cameras Product Support Page

5. Click the Resources tab.
6. Click the relevant **Download** link to download the resource you need.

## 2.2 Camera Dimensions

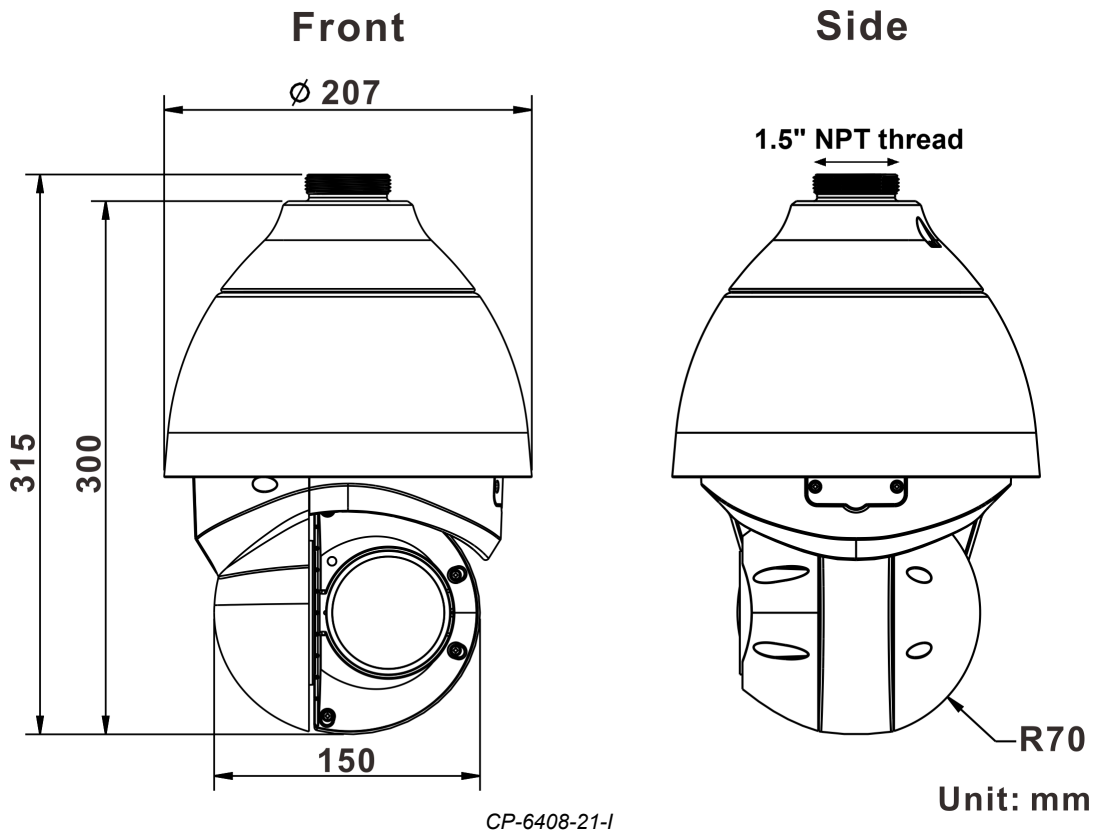

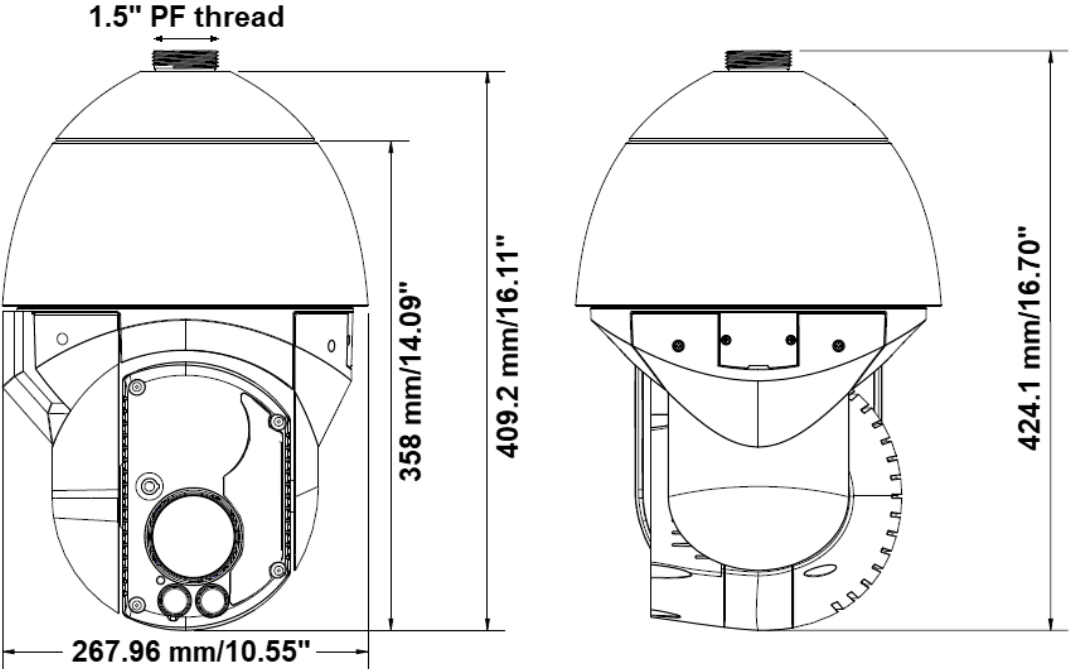

CP-6408-31-I



# 3 Installation

This camera can be installed outdoors or indoors.





For outdoor installation, FLIR recommends:

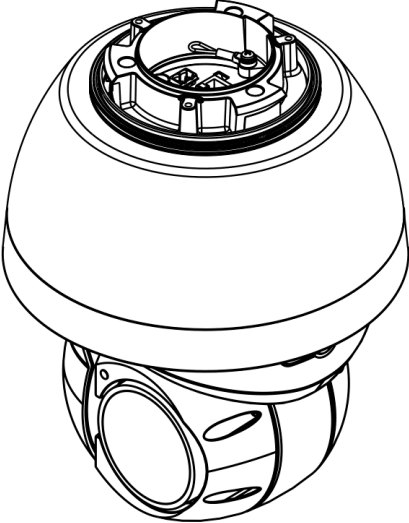
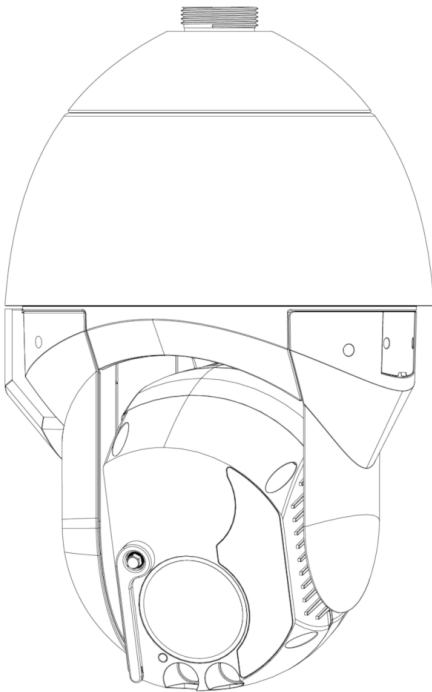

- Always using weatherproof equipment, such as boxes, receptacles, connectors, etc.
- For electrical wiring, using the properly rated sheathed cables for conditions to which the cable will be exposed (for example, moisture, heat, UV, physical requirements, etc.).
- Planning ahead to determine where to install infrastructure weatherproof equipment. Whenever possible, ground components to an outdoor ground.
- Using best security practices to design and maintain secured camera access, communications infrastructure, tamper-proof outdoor boxes, etc.

All electrical work must be performed in accordance with local regulatory requirements.

## 3.1 Supplied Components

The following table shows the items included in the CP-6408 camera kit (not to scale):

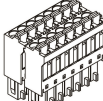
CP-6408-21-I	CP-6408-31-I
 <p data-bbox="509 1444 636 1472">Camera Body</p>	 <p data-bbox="883 1612 1182 1640">Camera Body and Pendant Cap</p>
 <p data-bbox="509 1598 636 1625">Pendant Cap</p>	 <p data-bbox="922 1682 1214 1730">Hard Ceiling Mount M5 Screw with Rubber Gasket</p>
 <p data-bbox="396 1682 688 1730">Hard Ceiling Mount M4 Screw with Rubber Gasket</p>	 <p data-bbox="786 1787 836 1814">O-ring</p>

CP-6408-21-I	CP-6408-31-I
 3-Pin 24 VAC Power Terminal Block	
 14-Pin Alarm/Audio I/O Terminal Block	
 2-Pin 12 VDC Power Terminal Block	 Safety Lanyard

### 3.2 Site Preparation

There are several requirements that should be properly addressed prior to installation at the site.

The following specifications are requirements for proper installation and operation of the unit:

- **Ambient Environment Conditions:** Avoid positioning the unit near heaters or heating system outputs. Avoid exposure to direct sunlight. Use proper maintenance to ensure that the unit is free from dust, dirt, smoke, particles, chemicals, smoke, water or water condensation, and exposure to EMI.
- **Accessibility:** The location used should allow easy access to unit connections and cables.
- **Safety:** Cables and electrical cords should be routed in a manner that prevents safety hazards, such as from tripping, wire fraying, overheating, etc. Ensure that nothing rests on the unit's cables or power cords.
- **Ample Air Circulation:** Leave enough space around the unit to allow free air circulation.
- **Cabling Considerations:** Units should be placed in locations that are optimal for the type of video cabling used between the unit and the cameras and external devices. Using a cable longer than the manufacturer's specifications for optimal video signal may result in degradation of color and video parameters.
- **Physical Security:** The unit provides threat detection for physical security systems. In order to ensure that the unit cannot be disabled or tampered with, the system should be installed with security measures regarding physical access by trusted and un-trusted parties.
- **Network Security:** The unit transmits over IP to security personnel for video surveillance. Proper network security measures should be in place to assure networks remain operating and free from malicious interference. Install the unit on the backbone of a trusted network.
- **Electrostatic Safeguards:** The unit and other equipment connected to it (relay outputs, alarm inputs, racks, carpeting, etc.) shall be properly grounded to prevent electrostatic discharge.

The physical installation of the unit is the first phase of making the unit operational in a security plan. The goal is to physically place the unit, connect it to other devices in the system, and to establish network connectivity. When finished with the physical installation, complete the second phase of installation, which is the setup and configuration of the unit.



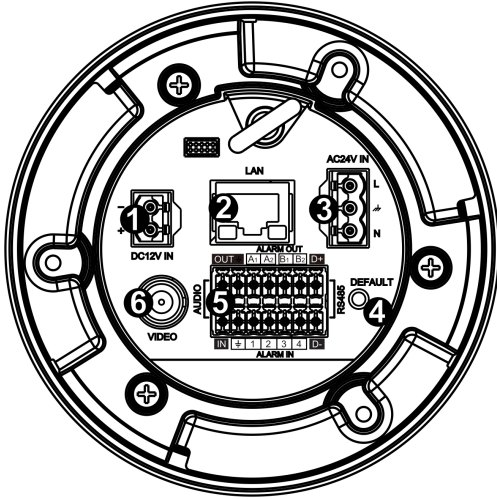

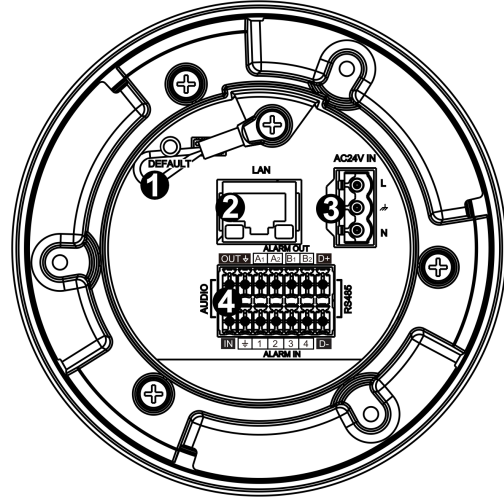

### 3.3 Camera Connections



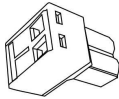

CP-6408-21-I Connectors

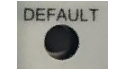
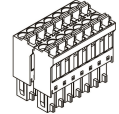

CP-6408-31-I Connectors

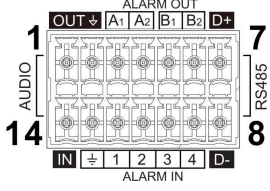
CP-6408-21-I	CP-6408-31-I	Connector	Connection	
1	N/A	DC12V IN	If using a 12 VDC power supply, connect its wires to the two-pin terminal block. See pin assignment below.  CP-6408-21-I: Do not use the DC12V IN and AC24V IN connectors at the same time.	
2	2	LAN	Attach a Cat 5e or Cat 6 cable from the network switch to the RJ45 LAN connector for a 10/100/1000 Mbps Ethernet and PoE connection. For information about using PoE, see <a href="#">Supplying Power to the Camera</a> . Verify that the LAN connector LEDs are steady green and flashing yellow.	
3	3	AC24V IN	If using a 24 VAC power supply, connect its wires to the three-pin power terminal block. See pin assignment below.  CP-6408-21-I: Do not use the DC12V IN and AC24V IN connectors at the same time.	
4	1	DEFAULT	To reset factory defaults at any time, press the Default button for at least 20 seconds.	
5	4	14-pin terminal block	Attach wires from external devices to the 14-pin terminal block connector for alarm and audio in/out (see diagram and definitions below).	
6	N/A	VIDEO	BNC connector for analog video output.	

14-Pin Terminal Block	Pin	Definition	Pin	Definition
	1	Audio-Out	8	CP-6408-21-I: RS-485 D- CP-6408-31-I: Not used
	2	Ground (Audio I/O)	9	Alarm-In 4
	3	Alarm-Out A1	10	Alarm-In 3
	4	Alarm-Out A2	11	Alarm-In 2
	5	Alarm-Out B1	12	Alarm-In 1
	6	Alarm-Out B2	13	Ground (Alarm I/O)
	7	CP-6408-21-I: RS-485 D+ CP-6408-31-I: Not used	14	Audio-In

DC12V IN Connector (CP-6408-21-I)	Pin	Definition
	1	-12 VDC
	2	+24 VDC

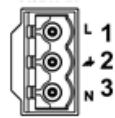
AC24V IN Connector	Pin	Definition
	1	AC 24L
	2	Ground
	3	AC 24N



**Note**

The CP-6408-21-I camera features zero downtime (ZDT) power switching. When the DC12V IN and PoE connections are both used, the camera draws power through the DC connection. If DC power fails, the camera switches power to the PoE connection until the DC power source is restored.



**Warning**

This product contains a battery that is soldered to the PCB. There is a risk of explosion if the battery is replaced by an incorrect type. **Do not replace the battery.** The battery should be disposed of in accordance with the battery manufacturer's instructions.

### 3.4 Supplying Power to the Camera

The camera can be powered by PoE or an external 12 VDC (CP-6408-21-I only) or 24 VAC power supply (not included in the camera kit).

- If using PoE, make sure the PoE switch or injector is a Power Sourcing Equipment (PSE) device.
- If using a PoE-capable network switch, the switch needs to support Universal PoE 60W 4 pair forced mode. For information regarding recommended switches, contact FLIR Support. **Note:** The camera does not support CDP/LLDP.
- If using a PoE injector, use a FLIR CP-POE-4P-60W-xx injector or contact FLIR Support for information about compatible injectors.
- If using an external AC or DC (CP-6408-21-I only) power supply, connect the power supply's wires to the appropriate power terminal block.

 **Warnings**

- Make sure the camera's power cable is properly connected. All electrical work must be performed in accordance with local regulatory requirements.
- Use a UL Listed Power Adapter that meets LPS (Limited Power Source) requirements.
- Note the camera's maximum power consumption:

CP-6408-21-I (12 VDC)

Mode	Current
Idle	0.7021A
Motor + camera on	0.8821A
Cold start only heater (camera off)	1.3423A
IR LED + camera on	1.8023A
IR LED + camera on + motor	2.1512A
IR + heater + camera on	2.6213A
IR + heater + motor + camera on	3.3121A

CP-6408-31-I

		LED	-40°C	25°C	60°C
<b>24 VAC (W)</b>	Camera static	Off	N/A	21	21
		On	27	43	43
	PTZ motion	Off	N/A	29	26
		On	57	50	49
	Maximum, including wiper and IRCUT		61	52	52
<b>PoE (W)</b>	Camera static	Off	N/A	15	15
		On	35	32	32
	PTZ motion	Off	N/A	22	19
		On	41	37	39
	Maximum, including wiper and IRCUT		43	39	42

- A PoE injector should be connected only to a PoE network inside a building and not routed outside the building.
- If the camera is installed outdoors with an external power supply, the power supply must be installed with proper weatherproofing.
- A qualified service person should install the camera.

### 3.5 Waterproofing the Camera

The camera is IP66-rated to prevent water from entering the camera. Nevertheless, water can enter the camera if it is not installed properly. Please make sure the warnings below are strictly followed when installing the camera.

1. Place all cables and the adaptor in dry and well-waterproofed environments, e.g. waterproof boxes. This prevents moisture accumulation inside the camera and moisture penetration into cables.

2. Seal the cable entry hole of the pendant cap with the rubber O-ring (supplied with the camera) and use thread seal tape to keep water from entering the camera.



*Waterproofing the Pendant Cap*

3. While running cables, slightly bend the cables in a U-shaped curve to create a low point. This prevents water from entering the camera along the cables from above.

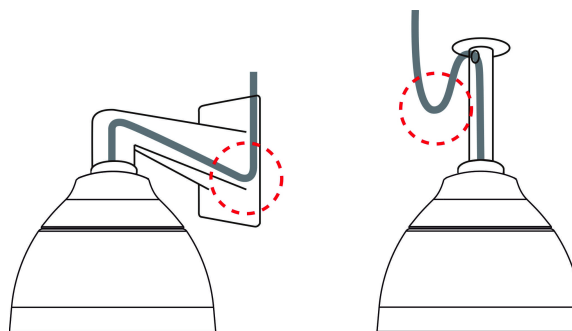

*U-Shaped Cable Installation*

### 3.6 Mounting the Camera

The following accessories and adapters are available for mounting the camera:

- [Wall Mount Bracket CX-ARMX-G3](#)
- [Corner Adapter CX-CRNR-G3](#)
- [Wall Mount Bracket with Power Box CX-ELBX-G3](#)
- [Pole Adapter CX-POLE-G3](#)
- [Gooseneck Mount with Power Box CX-GSNK-G3](#)

#### 3.6.1 Securing the Camera

When using either [Wall Mount Bracket CX-ARMX-G3](#) or [Wall Mount Bracket with Power Box CX-ELBX-](#)

**G3** with a CP-6408 camera, you need to secure the camera using a safety lanyard.

1. Before attaching the mounting accessory to the mounting surface, attach the safety lanyard to a secure anchor point on the mounting surface or on the accessory.
2. through the mounting accessory and through the pendant cap.
3. Attach the lanyard to the safety ring on the camera.
4. Route the power, Ethernet, and other cables through the mounting accessory and attach the mounting accessory to the mounting surface.
5. Route the power, Ethernet, and other cables through the pendant cap and attach the pendant cap to the mounting accessory.
6. Connect the cables to the camera.
7. Carefully insert the camera into the pendant cap and rotate the camera until it locks into place (1/3 turn).

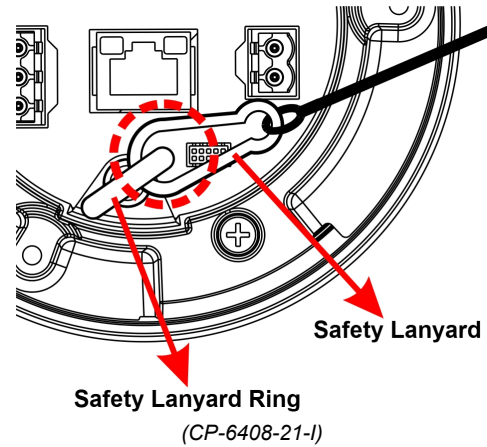



**Warning:**

The metal locking mechanism carries the weight of the camera. If the camera is not locked into place, it could become loose and fall.

The screw that attaches the pendant cap to the camera needs to line up with one of the corresponding screw holes on the camera.



Pendant Cap Screw

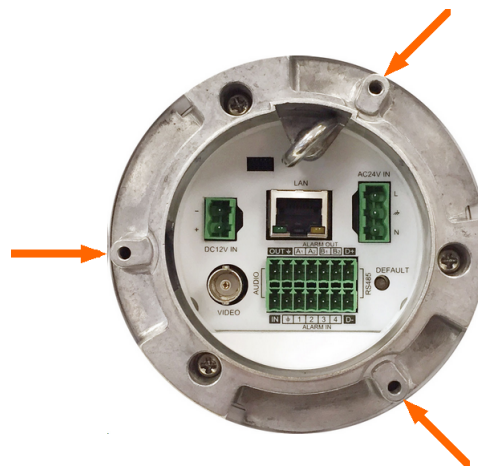

Pendant Cap Screw Holes on Camera  
(CP-6408-21-I)

8. Securely tighten the pendant cap screw into the camera. The screw prevents the camera from rotating.
9. Try to rotate the camera and make sure it is not possible to rotate the camera.





**Warning:**



If the camera can be rotated, it could become loose and fall.

### 3.6.2 Wall Mount Bracket CX-ARMX-G3

Wall mount bracket (1.5 inch threaded).

Item	Details	Qty
Wall mount bracket	CX-ARMX-G3	1
Parts package	No. 3 Allen key	1
	Sponge	2
Quick install guide	Summarized below	1

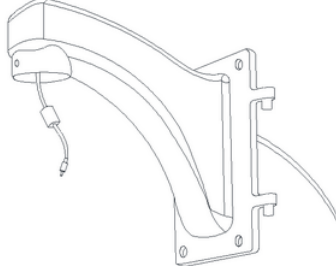
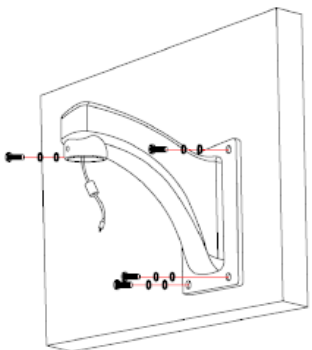
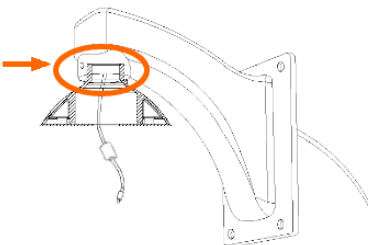

<p><b>Step 1</b></p>  <p>sponge no. 1</p> <p>Place the smaller, green sponge inside the bracket and route the cables through the center of it, as shown. You might need to cut a slit in the sponge.</p>	<p><b>Step 2</b></p>  <p>sponge no. 2</p> <p>Place the larger, black sponge inside the bracket, as shown. Route the cables through the pre-cut cross in the sponge.</p>	<p><b>Step 3</b></p>  <p>Route the cables through the bracket.</p>
<p><b>Step 4</b></p>  <p>Affix the bracket to the wall using the appropriate screws and screw anchors (not provided).</p>	<p><b>Step 5</b></p>  <p>Use the Allen key and a hex head cap screw to assemble and firmly affix the camera's pendant cap to the bracket.</p>	



**CX-ARMX-G3 dimensions**

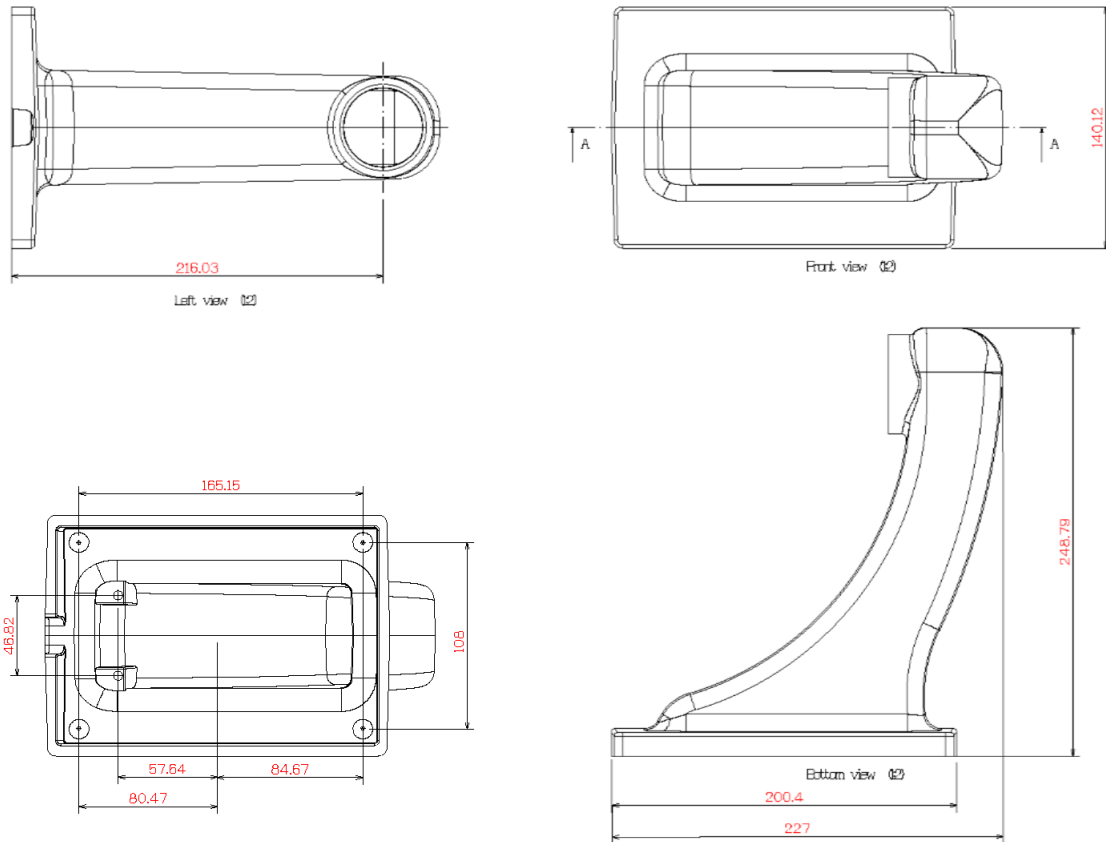

**3.6.3 Wall Mount Bracket with Power Box CX-ELBX-G3**

**What's in the Box**

Item	Details	Qty
Wall mount bracket with power box	CX-ELBX-G3	1
Parts package	NO. 3 Allen Key	1
	NO. 5 Allen Key	1
	Sponge	1
	Hex Head Cap screw M6 x 20 (stainless steel)	2
	Cable gland	1
Quick Install Guide	(this document)	1

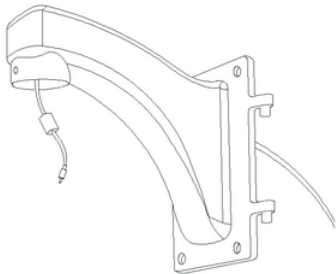
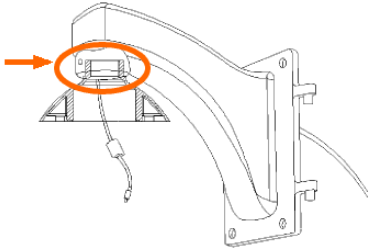
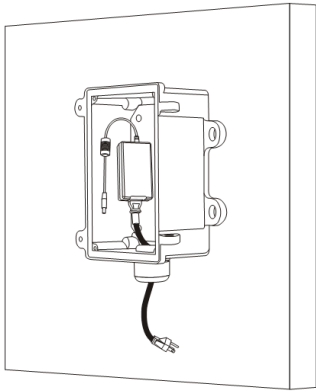
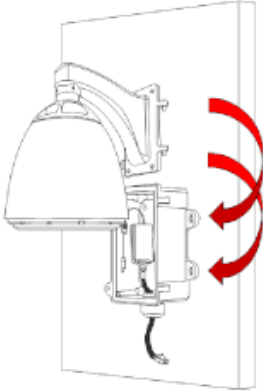
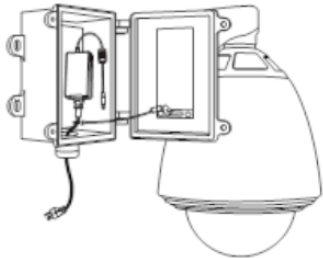

<p><b>Step 1</b></p>  <p>Place the sponge inside the bracket and route the cables through the center of it, as shown. You might need to cut a slit in the sponge.</p>	<p><b>Step 2</b></p>  <p>Route the cables through the bracket.</p>	<p><b>Step 3</b></p>  <p>Follow camera instructions to assemble the pendant cap. Use the Allen key and a hex head cap screw to assemble and firmly affix the camera's pendant cap to the bracket.</p>
<p><b>Step 4</b></p>  <p>Affix the power box to the wall or to the column.</p>	<p><b>Step 5</b></p>  <p>Attach the bracket to the power box.</p>	<p><b>Step 6</b></p>  <p>Buckle up the safety rope, make the camera connections, tighten the two hex screws to seal the box, and then complete assembly.</p>

### 3.6.4 Gooseneck Mount with Power Box CX-GSNK-G3

Gooseneck mount (1.5 inch threaded) with IP68 power box.

Item	Details	Qty
Gooseneck bracket and power box	CX-GSNK-G3 box	1
	CX-GSNK-G3 gooseneck pipe	1
Accessory box	No. 2 Allen key	1
	No. 3 Allen key	1
	No. 5 Allen key	1
	No. 6 Allen key	1
	M4x8 hex cap double washer	2
Quick install guide	Summarized below	1

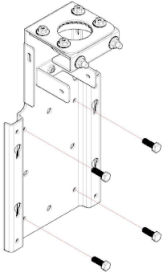
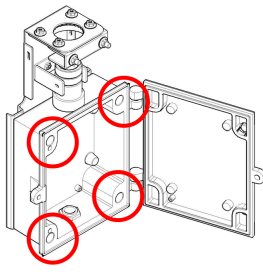
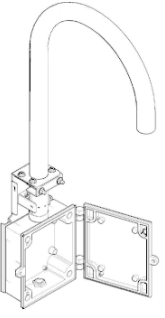
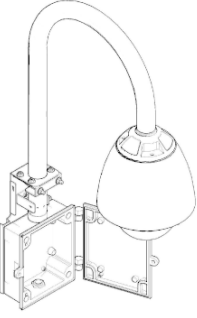
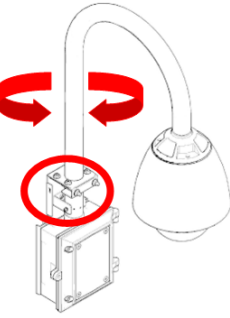
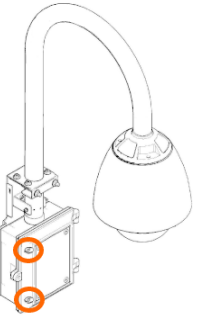

<p><b>Step 1</b></p>  <p>Fix backplate on mounting surface.</p>	<p><b>Step 2</b></p>  <p>Assemble power box and tighten screws with No. 6 Allen key.</p>	<p><b>Step 3</b></p>  <p>Assemble gooseneck pipe on backplate and power box.</p>
<p><b>Step 4</b></p>  <p>Attach pendant cap to gooseneck pipe, complete cable connections, and connect camera to pendant cap.</p>	<p><b>Step 5</b></p>  <p>Rotate gooseneck pipe to the position required. Tighten hexagon nuts to the flange and use No. 3 Allen key to tighten M4x8 hex socket screws.</p>	<p><b>Step 6</b></p>  <p>Use No. 6 Allen key to fix cover screws.</p>

**CX-GSNK-G3 dimensions**

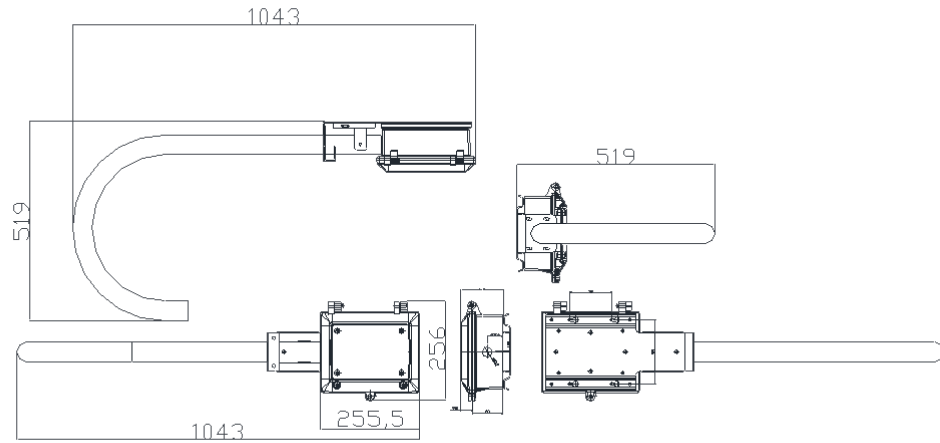

**3.6.5 Mount Adapters**

The following mount adapters are available for the camera:

- [Corner Adapter CX-CRNR-G3](#)
- [Pole Adapter CX-POLE-G3](#)

**3.6.5.1 Corner Adapter CX-CRNR-G3**

90-degree exterior angle corner adapter for CX-xxxx-G3 mounts.

Item	Details	Qty
Corner mount adapter	CX-CRNR-G3	1
Accessory bag	Stainless steel truss head screw M8*25	4
	Stainless steel truss head screw M8*30	4
	M8 washer	6
	M8 screw nut	6
	M8 spring washer	6
Quick install guide	Summarized below	1

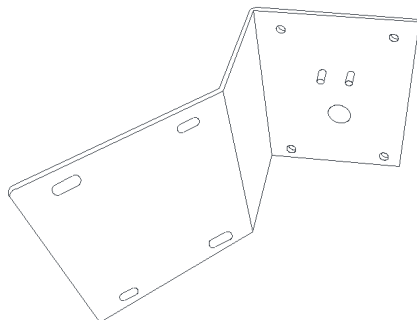
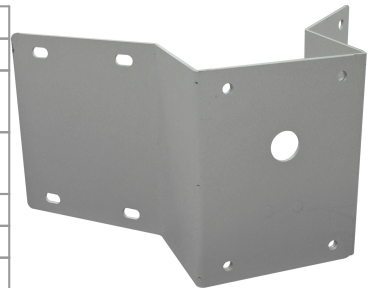

Part 1

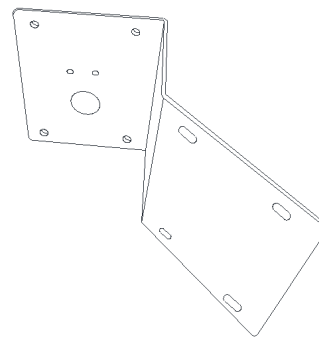

Part 2

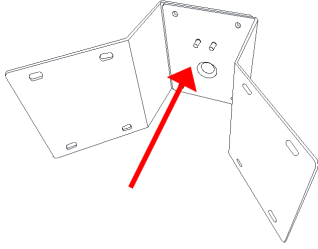
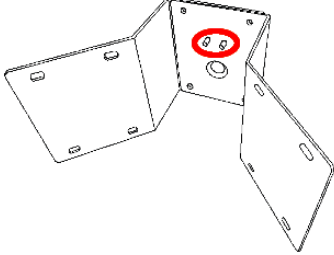
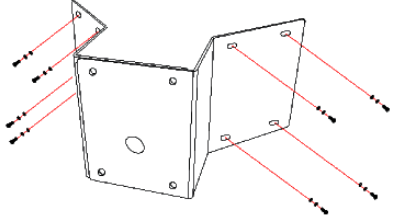
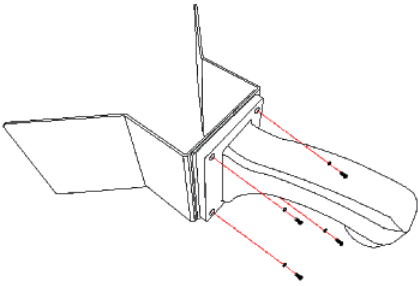
<p><b>Step 1</b></p>  <p>Join parts 1 and 2 together.</p>	<p><b>Step 2</b></p>  <p>Tighten hex head cap screws (clockwise).</p>	<p><b>Step 3</b></p>  <p>Fix assembled corner adapter to the wall.</p>
<p><b>Step 4</b></p>  <ul style="list-style-type: none"> <li>• When using a wall mount bracket (pictured), affix the wall mount bracket onto the corner adapter with washers in the front and screw nuts at the back.</li> <li>• When using a power box, affix the power box onto the corner adapter.</li> </ul>		

**CX-CRNR-G3 dimensions**

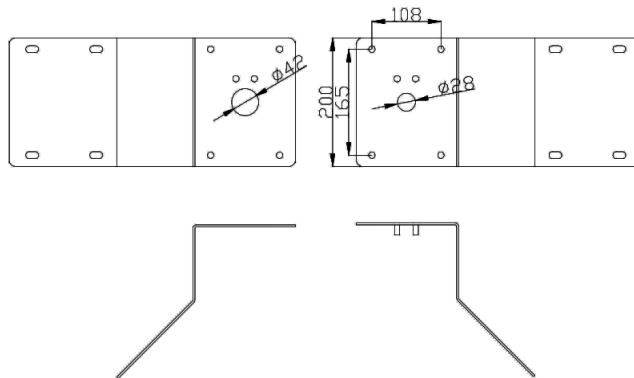

### 3.6.5.2 Pole Adapter CX-POLE-G3

Pole adapter for CX-xxxx-G3 mounts, including 2.5-8.5 inch straps.

Item	Details	Qty
Pole mount adapter	CX-POLE-G3	1
	8.5" ring	3
Accessory bag	Stainless steel truss head screw M8*20	4
	Stainless steel truss head screw M8*30	4
	M8 washer	4
	M8 screw nut	4
	M8 spring washer	4
Quick install guide	Summarized below	1



#### Step 1

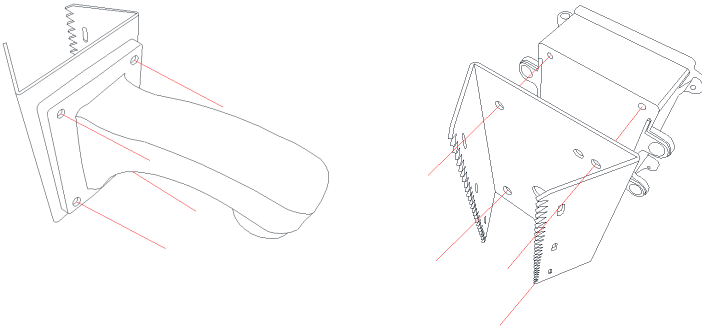

- When using a wall mount bracket, affix the wall mount bracket onto the pole adapter.
- When using a power box, screw power box onto the pole adapter.

#### Step 2

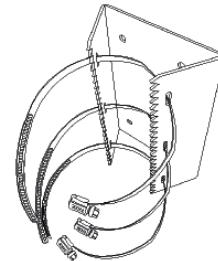

Thread the hoops through the CX-POLE-G3.

#### Step 3

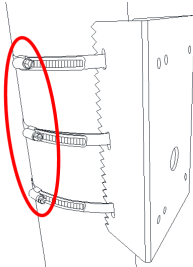

Fasten hoops tightly with flat-head screwdriver.

#### CX-POLE-G3 dimensions

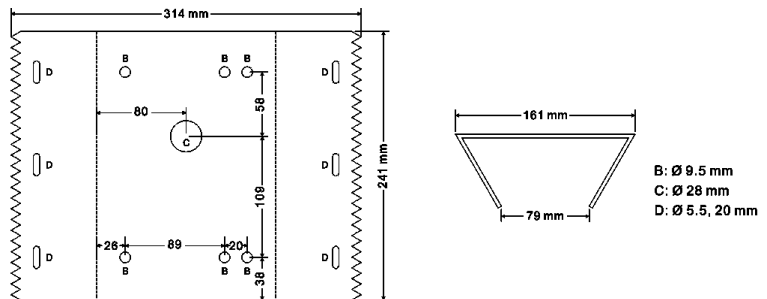

## 3.7 Initial Configuration

You can configure the camera using the DNA tool, the camera's web page, or a VMS.

	DNA tool	Camera's web page
Discover camera IP address	•	
Configure IP address, mask, and gateway	•	•
Configure DNS settings, MTU, and Ethernet speed		•
Change user credentials	•	•
Change video format	•	•
Configure more than one camera at the same time	•	



### Notes

- The DNA tool does not require a license to use and is a free download from the product's web page on [FLIR.com](http://FLIR.com). For more information about using the DNA tool, including how to configure more than one camera at the same time, see the *DNA User Guide*. While the software is open, click the Help icon .
- For more information about using a VMS to configure one or more cameras at the same time, see the VMS documentation.

To configure the camera for the first time, do the following:

- [Configure for Networking](#)
- [Change the Video Format \(optional\)](#)
- [Install and Test the Optional Wash Kit](#) (CP-6408-31-I only)
- [Attach the Camera to a VMS](#)

### 3.7.1 Configure for Networking

By default, DHCP is enabled on the camera and a DHCP server on the network assigns the camera an IP address. For example, if the camera is managed by FLIR's Horizon or Meridian VMS and the VMS is configured as a DHCP server, the VMS automatically assigns the camera an IP address.

If the camera is managed by FLIR's Latitude VMS or is on a network with static IP addressing, you can manually specify the camera's IP address using the DNA tool or the camera's web page. The camera's default IP address is 192.168.0.250.

#### To configure the camera for networking using the DNA tool:

1. Make sure the camera and the PC are on the same LAN segment.
2. Run the DNA tool (DNA.exe) by double-clicking . The Discover List appears, showing compatible devices on the VLAN and their current IP addresses.

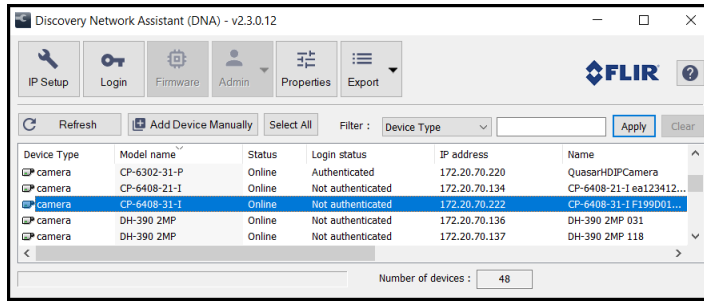

In the DNA Discover List, verify that the camera's status is *Online*.

If this is the first time you are configuring the camera or if it is the first time after resetting the camera to its factory defaults, DNA automatically authenticates the camera with the default password for the camera's admin user (*admin*).

If the admin user password has been changed, you need to authenticate the camera.

In the DNA Discover List, right-click the camera and select **Login**.

In the **DNA - Login** window, type the password for the admin user. If you do not know the admin user password, contact the person who configured the camera's users and passwords.

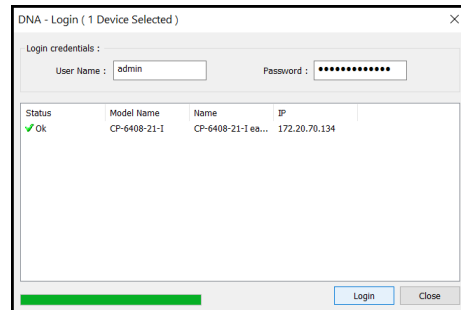
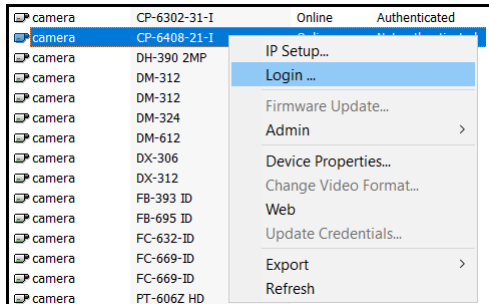

Click **Login**, wait for ✓ Ok status to appear, and then click **Close**.

In the DNA Discover List, verify that the camera's status is *Authenticated*.

3. Change the camera's IP address.

Right-click the camera and select **IP Setup**.

In the **DNA - IP Setup** window, clear *Use DHCP* and specify the camera's *IP address*. You can also specify the *Mask* (default: 255.255.255.0) and *Gateway*. Then, click **Update**, wait for ✓ Ok status to appear, and then click **Close**.

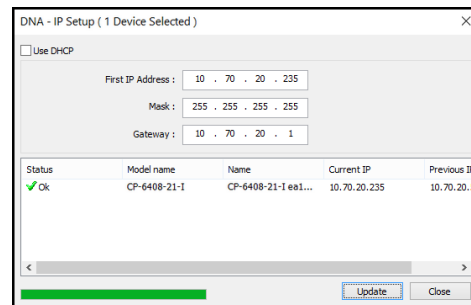

To manually specify the camera's IP address using the camera's web page:

1. [Access the camera's web page](#).
2. On the [View Settings Home Page](#), click **System Settings**, and make sure the [Network page](#) appears.



- Click **Static** IP addressing and then manually specify the camera's *Hostname*, *IP address*, *Netmask*, and *Gateway*.

You can also specify the *DNS Mode*, *Name Servers*, *MTU* (maximum transmission unit), and *Ethernet Speed*.

- Click **Save**. Applying any changes on the Network page requires reboot the camera.

### 3.7.2 Change Video Format (Optional)

By default, NTSC is the camera's video format.

#### To change the camera's video format to PAL using the DNA tool:

- In the DNA Discover List, right-click the camera and select **Change Video Format**.
- In the **Change Video Format** window, select PAL.
- Click **Update**, wait for ✓ Ok status to appear, and then click **Close**.

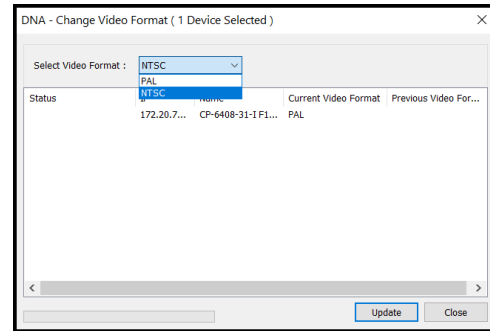

#### To change the camera's video format to PAL using the camera's web page:

- Open the [Visible Page](#).
- Click **Advanced Settings**.
- For **Video Format**, click PAL.

To apply a change to the **Video Format** setting, the camera needs to reboot.

### 3.7.3 Install and Test the Optional Wash Kit

As an optional accessory for the CP-6408-31-I camera, FLIR recommends the Videotec line of wash kits for PTZ cameras, including the WASPT0V5L5M00 washer pump, five-liter tank, five-meter delivery kit. For general information about installing a Videotec wash kit, see the kit's instructions manual.

This section and this guide contain important information about installing the washer and using it specifically with the CP-6408-31-I camera.

#### Connection of the board

Connect the following:

J9 terminal on the washer pump control board		Camera's 14-pin terminal connector
CP pump activation (dry contact)	➔	Alarm-Out A1 pin (3)
GCP GND pump activation (dry contact)	➔	Alarm-Out A2 pin (4)

#### Washer installation (CP-6408-31-I)

- Cut the cables to size and either restore or make the connections to the positioning unit.

2. Shorten the semi-rigid washer pipe (01) as needed. Unscrew the nut (02) from the joint and slide it along the pipe. Insert the end of the pipe into the ogive (03).

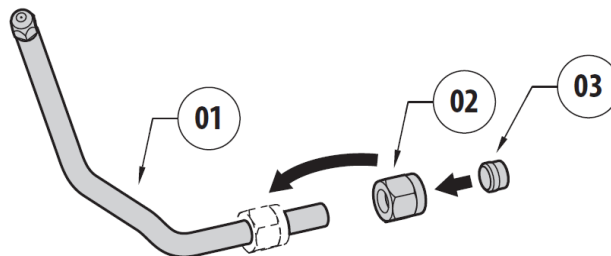

3. Lock the nut to the coupling.

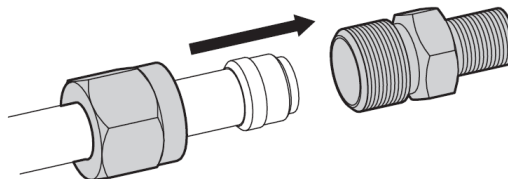

4. Tighten the delivery joint.

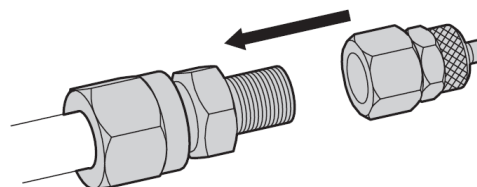

5. Unscrew the knurled nut (01) from the delivery joint (02). Insert the knurled nut on the delivery pipe (03). Insert the end of the delivery pipe into the spinner (04). Lock the nut to the coupling.

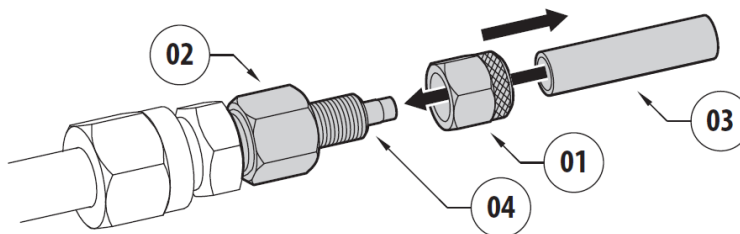

6. Fasten the semi-rigid pipe and aim the nozzle towards the camera lens window. Depending on how and where you are installing the camera and the wash kit, you can use one of the nozzle support brackets supplied with the wash kit to secure and aim the nozzle.



**Important**

When you test the wash kit, you will set the camera's washer position using the camera's web page. Aim the washer nozzle so that it sprays liquid over the camera lens window when the camera is in what will be its washer position. Activating the camera's wiper when the lens window is dry causes irreparable damage to the window coatings and voids the camera's warranty.

**Make sure the camera's I/O settings activate the washer pump**

1. With a user assigned the admin or expert role, log in the camera's web page. For information about how to log in to the camera's web page, see [Accessing the Camera](#).

2. Open the [I/O Devices Page](#).
3. Select local output 1.
4. Make sure the following local output 1 default settings are specified:

Setting	Value
State	Off
Idle State	Open
Reset Interval	0 seconds (automatic output pin reset is disabled)

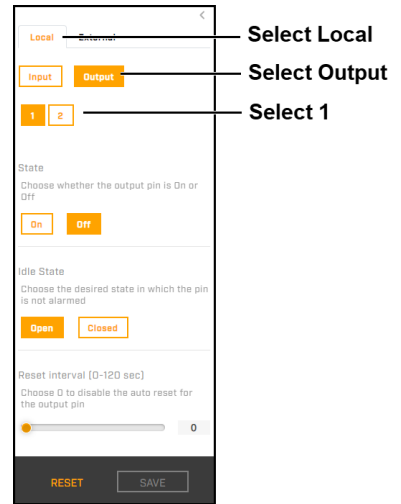

### Testing the washer and wiper

Before testing the washer and wiper, make sure you:

- Install the wash kit according to the kit's instructions manual and according to the instructions above.
- Fill the washer liquid tank.

1. Using the camera's web page, open the Wiper page.
2. Under **Washer device installed**, click **On**. To apply the change to this setting, the camera needs to reboot. After the camera reboots, log back in and open the Wiper page.

3. Set the washer position.

Click **Advanced Settings**.

Under **Washer Position**, use the PTZ controls to move the camera into a position so that the washer sprays liquid over the camera lens window.

Click **Set**. The camera saves its current pan and tilt position as the washer position.

You can also specify a wash spray duration between 0-10 seconds.

4. Activate the washer.

Under **Washer**, click **Start**. Make sure the washer activates.

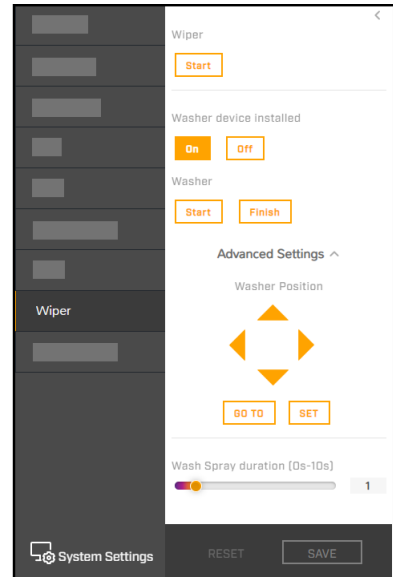

### Important

If the initial washer position does not spray liquid over the camera lens window, reset the washer position and try again.

2. Activate the wiper.
- Under **Wiper**, click **Start**. Make sure the wiper performs one full wiper cycle.



**Caution**

Before activating the wiper, make sure the lens window is wet. Using the wiper when the window is dry causes irreparable damage to the window coatings and voids the warranty.

### **3.7.4 Attach the Camera to a VMS**

After you have mounted the camera and discovered or defined its IP address, you can use VMS Discovery/Attach procedures to attach the camera to a VMS.

## 4 Operation

This chapter includes information about how to [access the camera](#) and how to operate it using the [View Settings page](#).

### 4.1 Accessing the Camera

To operate the camera, you first need to access it. You can access the camera by either logging in to the camera's web page. The camera's web page supports Google Chrome® and other popular web browsers.

**To log in to the camera's web page:**

1. Do one of the following:
  - In the FLIR Discovery Network Assistant (DNA) tool, double-click the camera in the Discover List.  
The DNA tool does not require a license to use and is a free download from the product's web page on [FLIR.com](http://FLIR.com). Download the DNA tool; unzip the file; and then double-click  to run the tool (DNA.exe). The Discover List appears, showing compatible devices on the VLAN.
  - Type the camera's IP address in a browser's address bar (when the PC and the camera are on the same network). If you do not know the camera's IP address, you can use the DNA tool to discover it.
2. On the login screen, type a user name and the password.

When logging in to the camera for the first time or for the first time after resetting the camera to its factory defaults, type admin for the user name and for the password.

If you do not know the user name or password, contact the person who configured the camera's users and passwords.

3. When logging in to the camera for the first time or for the first time after resetting the camera to its factory defaults, specify a new password for the admin user and then log back in using the new password.

Use a strong password consisting of at least 12 characters and at least one uppercase letter, one lowercase letter, and one number.

Passwords can include the following special characters: |@#~!\$&<>+\_-.,\*?=. .

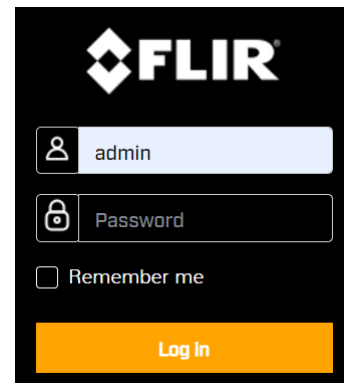

The camera's [View Settings home page](#) appears.

### 4.2 View Settings Home Page

The View Settings page displays live video images. When a user assigned the expert or admin role logs in to the camera's web page, the page also displays View Settings menus along the left side banner and other options.

**View Settings menus**

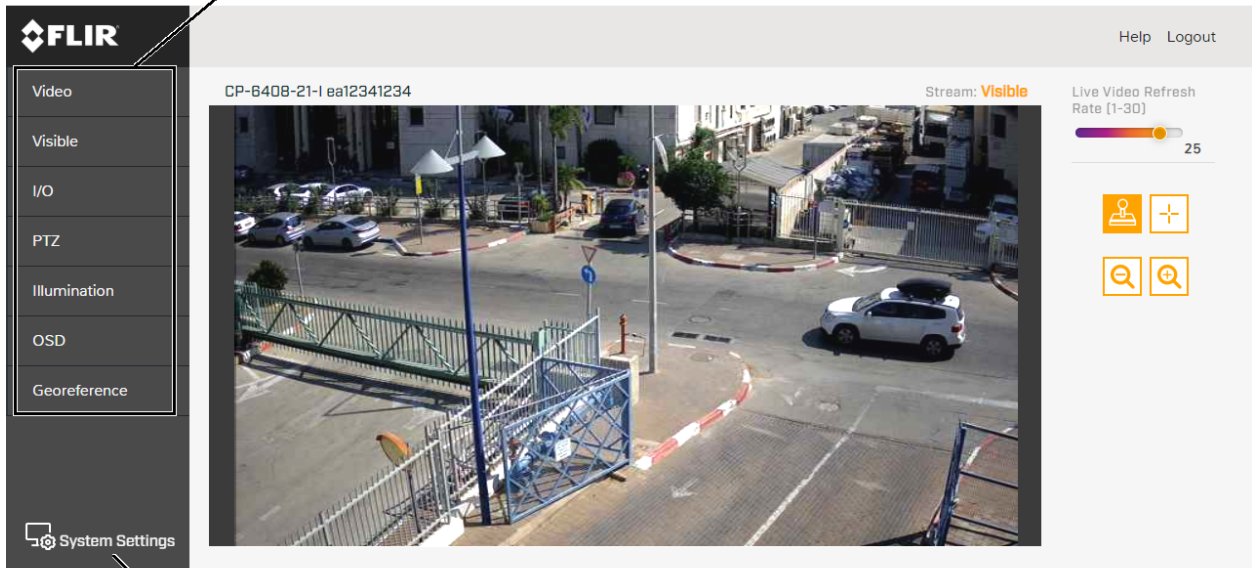

**System Settings**

*CP-6408-21-I View Settings page for users assigned the admin or expert role*

**View Settings menus**

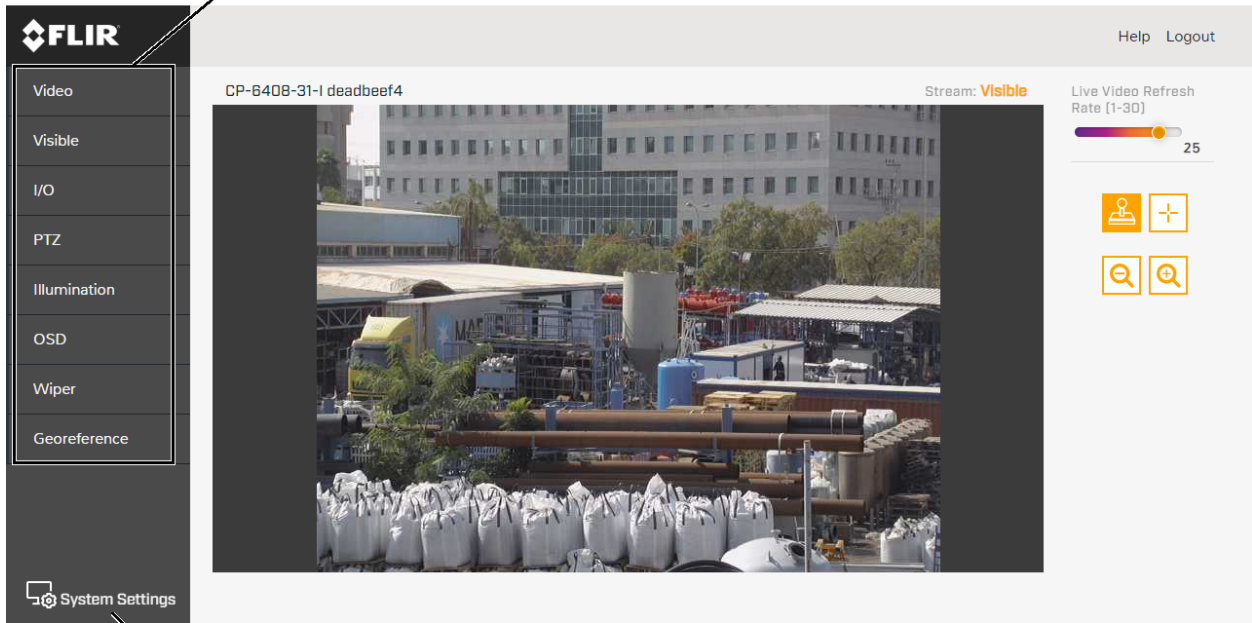

**System Settings**



*CP-6408-31-I View Settings page for users assigned the admin or expert role*

**Live Video**

You can set the Live Video Refresh Rate between 1-30 image frames per second (FPS). The Live Video Refresh Rate setting only affects the live video; it does not affect the camera's video streams.

### Pan, Tilt, and Zoom (PTZ)

You can toggle controlling the camera's pan and tilt between:

	Emulated Joystick	When the mouse pointer is over live video, it becomes a directional arrow. To move the camera, you can: <ul style="list-style-type: none"> <li>• Click and release—Moves the camera once.</li> <li>• Click and hold—Moves the camera until it reaches its physical limit or you release.</li> <li>• Click and drag—Moves the camera as you drag the mouse.</li> </ul>
	Crosshairs	When the mouse pointer is over live video, it becomes a crosshairs. Clicking and releasing centers the camera on the crosshairs location.

You can zoom in and out using:

- The onscreen buttons—Click once or click and hold for continuous zoom.
- The mouse wheel, when the mouse pointer is over live video.



**Tip**

Zooming in and out affects the video streams, unlike the Live Video Refresh Rate setting.

### System Settings and Other Options

Users assigned the admin or expert role can click **System Settings** to configure the camera. For more information, see the [Configuration](#) chapter.

Additional choices are for Help and Logout.

## 4.3 Video Page

The camera provides two video streams (V1 and V2). Video streams are available for viewing using a client program or third-party ONVIF systems.

In general, it is not necessary to modify the default parameters. In some cases, such as when an IP video stream is sent over a wireless network, it can be useful to tune the video streams to reduce the bandwidth requirements. To modify the parameters for a particular video stream, click the relevant button (V1 or V2).

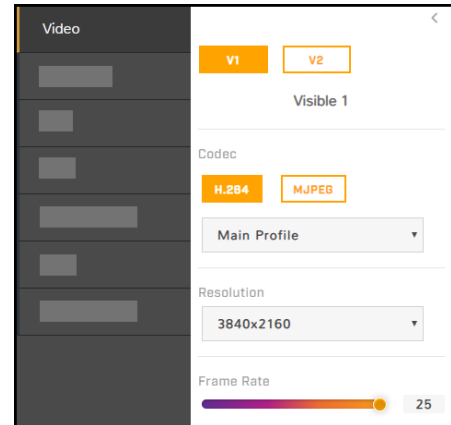

**Tip**

On the camera web page, the live video is not the actual video stream. Changes to stream settings might not affect the live video. Check any changes to stream settings using a client program or third-party ONVIF system.

### Visible 1 / Visible 2

Codec options for the visible streams are H.264 or MJPEG.

Resolution options are 3840x2160 (4K), which is available only with H.264 encoding; 1920x1080 (1080p); 1280x720 (720p); and 640x480 (480p). The Frame Rate range is 5-30 FPS (frames per second).

When one stream's resolution is set to 3840x2160, the camera supports the following resolutions for the other stream:

One visible stream		Other visible stream	
Resolution	Frame rate	Resolution	Frame rate
3840x2160	> 15 FPS	640x480	≤ 30 FPS
	≤ 15 FPS	1280x720	
		1920x1080	

**Codecs, Quality, and Bandwidth**

The codec used determines which parameters you can set that have a significant impact on the quality and bandwidth requirements of the video stream. Use the default values initially, and then individual parameters can be modified and tested incrementally to determine when bandwidth and quality requirements are met.

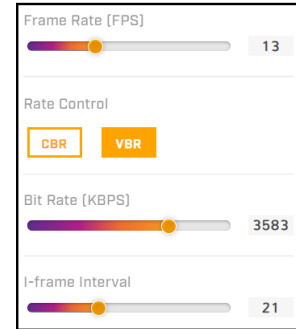

With the H.264 codec, you can set the:

- Rate Control:
  - CBR (constant bit rate): The Bit Rate parameter defines the target bit rate; the camera attempts to keep the video at or near the target bit rate.
  - VBR (variable bit rate): The Bit Rate parameter defines the average bit rate.
- I-frame Interval: Controls the number of P-frames used between I-frames. I-frames are full frames of video and the P-frames contain the changes that occurred since the last I-frame. A smaller I-Frame Interval results in higher bandwidth (more full frames sent) and better video quality. A higher I-frame Interval means fewer I-frames are sent and therefore can result in lower bandwidth and possibly lower quality.

With the MJPEG codec, you can set the Quality between 10-80. Setting a higher value can increase the video stream's bandwidth requirements.

**Network Options**

By default, multicast is enabled. Multicast video packets are shared by streaming clients. Additional clients do not cause bandwidth to increase as dramatically as with unicast. Video stream requests for ch0/stream1 are unicast. Client-specific multicast requests vary according to the client.

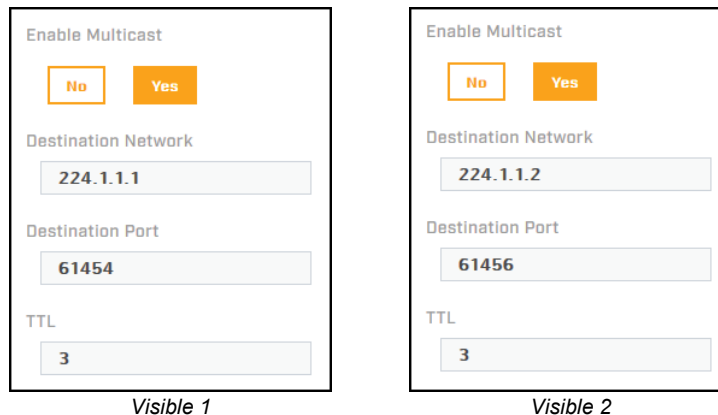

If more than one camera is providing multicast streams on the network, make sure the Destination Network IP address is unique for each camera (the Destination Port can be reused). By default, the port assignment is unique per stream.



The time-to-live field controls the ability of IP packets to traverse network boundaries. A value of 1 restricts the stream to the same subnet. Greater values allow increasing access between networks.

The video streaming uses a protocol generally referred to as RTP, the real-time transport protocol, although there are actually a number of protocols involved, including the Real-Time Streaming Protocol (RTSP). The video stream URLs incorporate the IP address of the camera. Using the camera's default IP address, the complete URLs are:

- **Visible 1**—rtsp://192.168.0.250:554/stream1
- **Visible 2**—rtsp://192.168.0.250:554/stream2

To maintain compatibility with legacy systems, the stream names are aliased as: ch0 = stream1 and ch1 = stream2.

Accessing any of the camera's video streams requires authentication. You can use the name and password for any of the camera's users. See [Users Page](#).

## 4.4 Visible Page

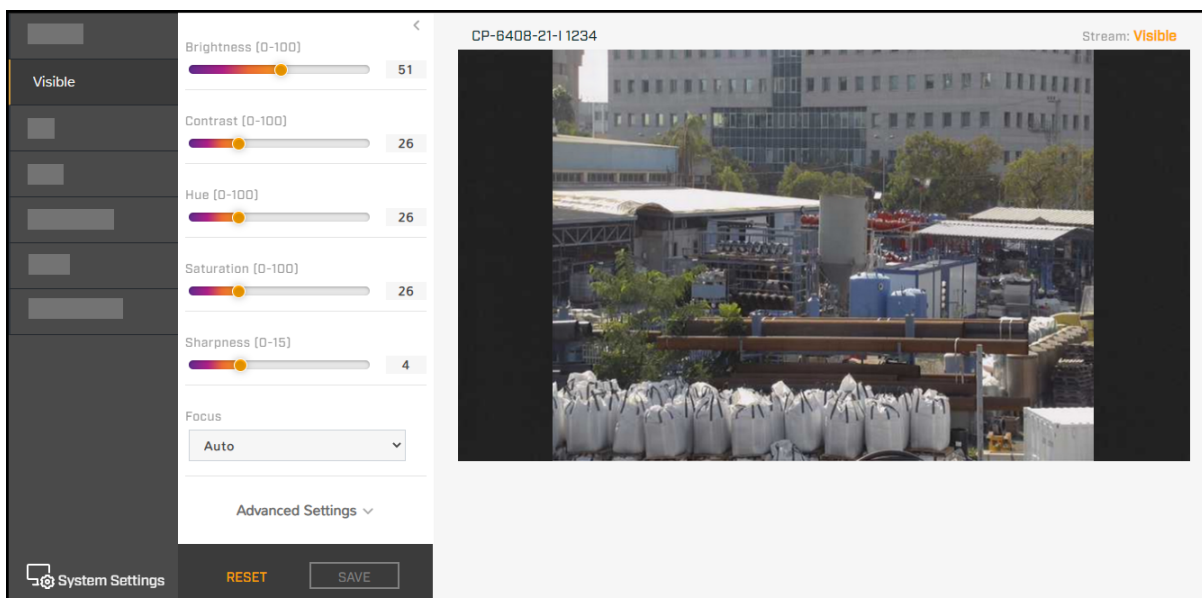

You can adjust the following visible video settings:

- **Brightness** (Gamma)
- **Contrast** (Max Gain)
- **Hue**
- **Saturation**
- **Sharpness**
- **Focus**—Select Auto for continuous auto-focus: The camera automatically and continuously maintains focus regardless of view changes. To manually focus the camera, select Manual.

## Advanced Settings

- **Night Mode**—Set the visible video to:

- **Color** (day mode)
- **B/W** (night mode)
- **Auto** (default)—Automatically switches the visible video mode according to light level. When Night Mode is set to Auto, you can set the thresholds at which the visible video switches from black and white to color (Night to Day Threshold) and vice versa (Day to Night Threshold). Move the sliders between 0-100, where 0 switches modes at a lower light level (darker) and 100 switches modes at a higher light level (brighter).

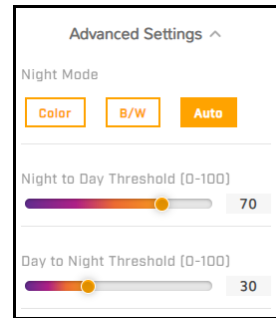

On the [Illumination Page](#), when infrared illumination is set to Auto and the scene becomes dark enough, the visible video automatically changes to B/W (night mode).

- **Wide dynamic range settings**

WDR improves the image quality and amount of detail in high contrast scenes. High contrast scenes consist of areas with different lighting conditions; some areas are bright and others are dark. Without WDR, either the bright areas would be overexposed (too bright) or the darker areas would be completely dark. WDR can produce more detail in both the dark and the bright areas of the image.

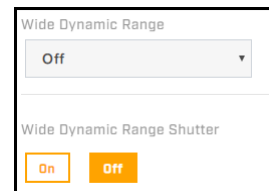

- **Wide Dynamic Range**—Set the level of digital Wide Dynamic Range (dWDR) to Off, Low, Mid, or High. When enabled, the camera digitally enhances the details in each frame.
- **Wide Dynamic Range Shutter**—Enables True WDR. The camera combines two frames taken with slow- and fast-exposure shutter speeds into a single frame with a wide dynamic range, determining the optimal mix of regions within the scene.

- **White Balance**—Set according to operating environment:

- **Auto** (default)—Computes the white balance value output using color information from the entire screen. It is suitable for an environment with a light source color temperature in the range of approximately 2,700 ~ 7,500K.
- **One Push**—Click One Push Trigger to activate the factory-optimized setting for white balance. This setting might not be ideal for every lighting environment.
- **ATW** (Auto Tracking White Balance)—Automatically adjusts the white balance in a scene while temperature color is changing. It is suitable for an environment with a light source color temperature in the range of approximately 2500 ~ 10,000K.
- **Manual**—Define the Rgain and Bgain between 0-100 to increase the red and blue luminance.

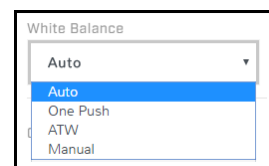

• **Noise reduction settings**

Noise reduction settings are used to reduce or eliminate artifacts that can limit the ability to positively identify an object. There are two types of noise: luminance and color (chroma) noise. 3D noise reduction and 2D noise reduction settings reduce luminance noise: dots of varying brightness levels (black, white, and gray). It is not recommended to completely eliminate luminance noise, which can result in unnatural images. The 3D Noise Reduction and 2D Noise Reduction settings should be configured after configuring Color Noise Reduction.

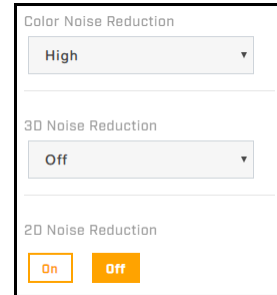

- **Color Noise Reduction**—Controls the noise appearing as red, green and blue dots between light and dark areas. Four settings are available: Off, Low, Mid, High. High maximizes the blending of the color noise with the image, effectively removing the dots, while Low minimizes the blending.
- **3D Noise Reduction**—Provides superior noise reduction and is recommended for use in extra low-light conditions. It is especially useful for reducing blur with moving objects. 3D noise reduction reduces image noise/snow in low-light conditions by comparing adjacent frames. A higher level of 3D noise reduction generates relatively enhanced noise reduction, although it creates more motion blur than 2D noise reduction on moving objects. Four settings are available: Off, Low, Mid, High.
- **2D Noise Reduction**—Analyzes individual frames pixel by pixel and frame by frame to eliminate environmental noise and deliver optimized image quality, especially in low-light conditions. 2D noise reduction tends to produce superior results for moving objects when applied to areas in the field of view where movement is present. However, it is less precise than 3D noise reduction. It can be set On or Off.

- **HLC (Highlight Compensation)**—Detects areas of the image overexposed by bright light sources such as headlights or spotlights and reduces image exposure only in these areas to enhance overall image quality. HLC works when Wide Dynamic Range Shutter is On.
- **Stabilization (Electronic Image Stabilization)**—CP-6408-21-I: Keeps the image steady and counteracts external vibration. To ensure calibration accuracy, after enabling stabilization, keep the camera still for three seconds. When Stabilization is On, the stabilization algorithm that processes the image slightly crops the video image. CP-6408-31-I: To be supported in a future release.
- **Digital Zoom**—Enable or disable digital zoom. Digital Zoom is not available when Stabilization is On.
- **Lidar Autofocus (CP-6408-31-I only)**—Enable or disable the camera's laser focus technology.
- **Exposure Mode**

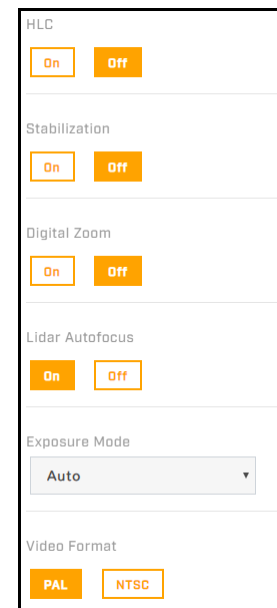

Exposure is the amount of light detected by the image sensor and is determined by the amount of time the shutter is open (shutter speed), and other exposure parameters.

- **Full Auto (default)**—The camera completely opens its shutter and automatically selects an exposure level using a programmed algorithm to achieve a consistent exposure output. Exposure priority is given to the iris. This mode is recommended for environments involving mixed lighting sources; for example, indoor scenes where the main source is fluorescent lighting, combined with natural light that enters the scene through windows and other exposed areas.

- **Manual**—Allows you to specify a fixed shutter speed, iris size, and gain. Generally used where light levels are fixed and the Full Auto mode does not provide the optimal exposure. This mode is recommended for scenes where there is a fixed lighting contrast and a constant, precise exposure is required; for example, some indoor scenes.

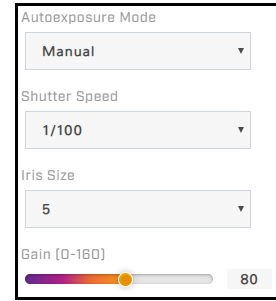

- **Shutter Speed**—Select a fixed shutter speed according to the environmental luminance. A slower shutter speed increases the amount of light entering the sensor and results in a brighter, more-detailed image. The Video Format determines the shutter speeds available, listed in the following table from slowest to fastest:

NTSC			PAL		
1/30	1/180	1/1000	1/25	1/150	1/1250
1/60	1/250	1/2000	1/50	1/215	1/2500
1/90	1/350	1/3000	1/75	1/300	1/3500
1/100	1/500	1/10000	1/100	1/425	1/10000
1/120	1/725	1/32000	1/120	1/600	1/32000

- **Iris Size**—The iris works in tandem with the shutter to determine how much light enters the sensor. Defining a larger iris increases the amount of light entering the sensor and results in a brighter, more-detailed image. With 0 (zero) being the smallest iris size, select a value between 0-9 or Full Open.
- **Gain**—A higher value increases the sensitivity of the image sensor, which brightens the image and adds details, but also increases the noise level. Define a value between 0-160.
- **Video Format**—When mounted indoors, the visible camera shutter speed can be synchronized to the 50 Hz or 60 Hz power used for lighting the scene. If lighting is connected to 50 Hz power, the PAL setting might provide better video and NTSC might provide better video under 60 Hz lighting.

Where relevant, changing the settings on the Visible page immediately affects the live visible video images and streams. To save any changes, click **Save**. To discard changes or return to the factory defaults, click **Reset**.

## 4.5 Input/Output (I/O) Page

Adjust local and external I/O settings on the I/O page.

- For local I/O connections:

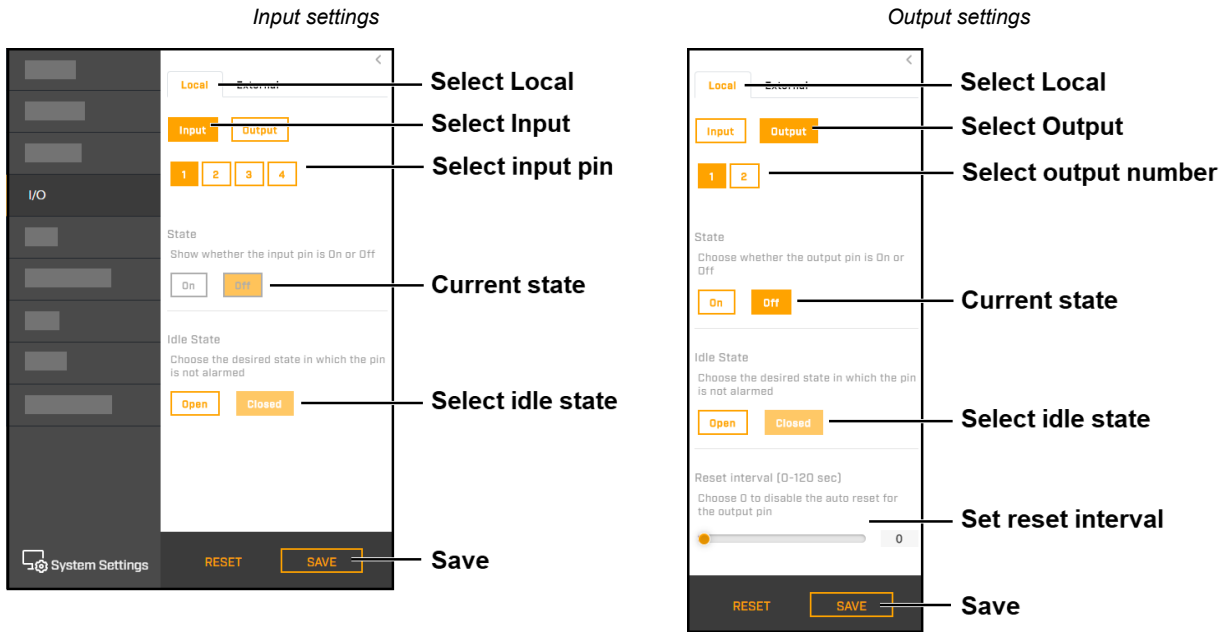

For information about the local I/O connector, see [Camera Connections](#).

- For external I/O connections, set the current state for the input and output pins, as shown at right.

You can configure the external I/O connections, including the number of external input and output pins, on the [I/O Devices Page](#) in System Settings.

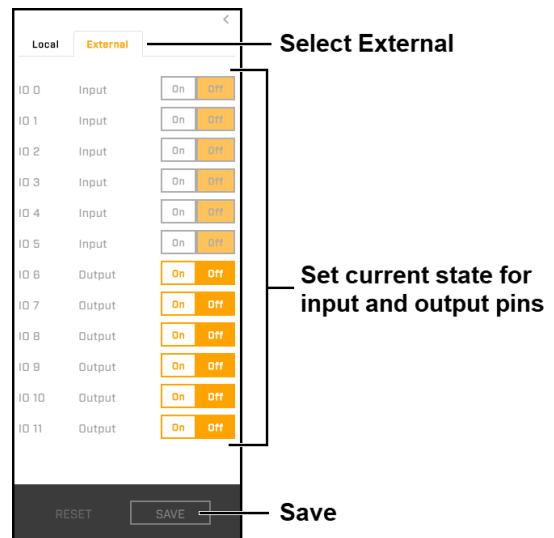

## 4.6 PTZ Page

Use the PTZ page to:

- Move the camera left, right, up, or down (pan and tilt)
- Define the pan and tilt speed, between 1x-10x
- Zoom in and out—click once or click and hold for continuous zoom
- Go to the camera's home position
- Set the camera's current position as its home position
- Define preset positions:
  - a. Under Preset Position, click **Set Preset**.
  - b. Select a preset index number from 1-128. Selecting an index number currently associated with a preset position overwrites the existing preset position.
  - c. Specify a unique, descriptive name for the preset position. You can use alphanumeric characters, underscores (\_), or dashes (-).
  - d. Click **Set**. The camera adds the current position as a preset.

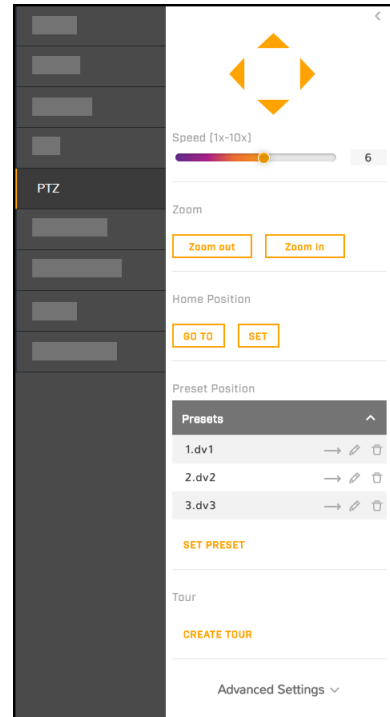
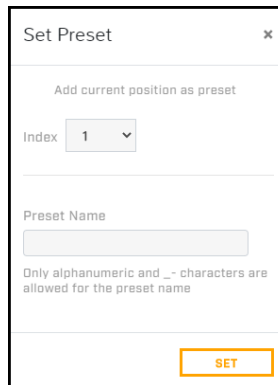

Preset positions are relative to the camera's orientation, which is defined on the [Georeference Page](#). If the camera's orientation changes and presets have been defined, redefine them with the new orientation setting.

- Move the camera to a preset position, edit a preset name, or delete a preset:

Under Preset Position, click **Presets**. The list of presets appears, in ascending index number order.

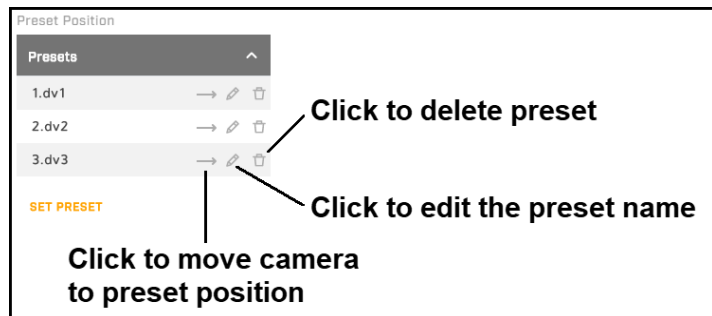



- Create and manage a tour of preset positions (only available if presets have been defined):

To create a tour, click **Create Tour**. For each tour stop, click **Add**, select a preset, and define the amount of time in seconds the tour stops at the preset.

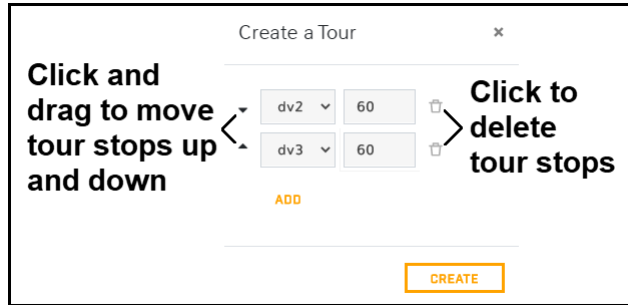
You can also move tour stops up or down in the list and delete tour stops.



After you create a tour, you can start , pause , stop , edit, or delete it.

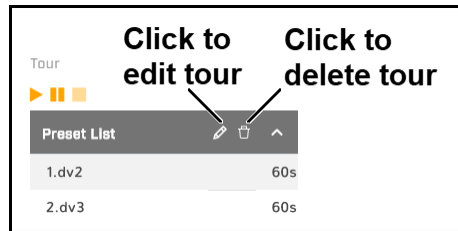

### Advanced Settings

- **Startup Mode**—You can specify that when the camera starts up, it automatically starts the tour of preset positions.
- **Mechanical Flip**—Disable or enable the camera's mechanic flip feature. By default, Mechanical Flip is set to On and the camera can continuously track an object passing under the camera. When a tilting camera reaches its maximum angle, it pans 180° and then continues tilting to keep tracking the object.

 **Note**

If a preset position or a point for another function (for example, a tour) is set to a position that can only be reached by flipping the camera, when Mechanical Flip is set to Off, the camera cannot reach that position.

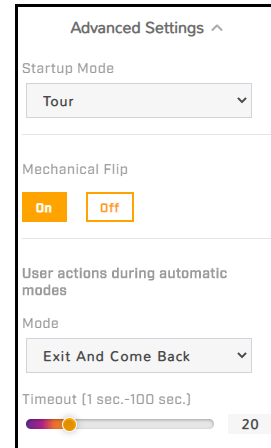

- **User actions during automatic modes**—You can specify the camera's behavior when a user attempts to manually move the camera during an automatic mode such as a tour:
  - **None** (default)—Disables manual camera movement.
  - **Exit**—The camera exits the automatic mode.
  - **Exit and Come Back**—The camera exits the automatic mode. After the specified **Timeout** or period of inactivity, between 1-100 seconds, the cameras resumes the automatic mode.

Where relevant, changing the settings immediately affects the live video and video streams. To save changes, click **Save**. To discard changes, click **Reset**.

## 4.7 Illumination Page

The camera features NIR illumination for the visible light camera. By default, infrared illumination is set to Auto; when the scene becomes dark enough, the infrared illumination turns on and the visible camera video changes to night mode (black and white video). You can set the night-to-day and day-to-night thresholds on the [Visible Page](#).

You can set the infrared illumination to Off.

To save a change to the setting as the power-cycle default, click **Save**.

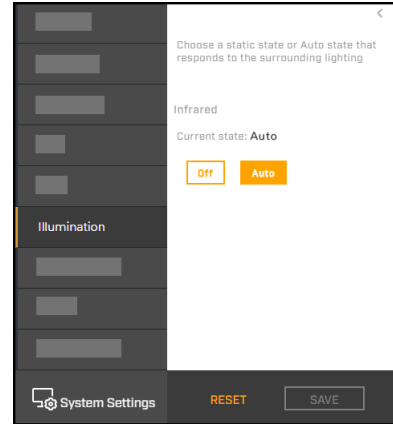

## 4.8 OSD Page

The OSD page provides separate on-screen display settings for visible video. The camera can overlay onto the video its name and the date and time:

- with either black or white text
- with or without a contrasting background
- in small, medium, or large size

Changes to OSD settings immediately take effect.



Visible video with OSD

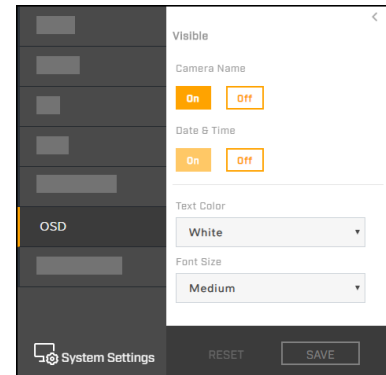

## 4.9 Wiper Page

The following settings and operations are available from the Wiper page (CP-6408-31-I only):

- **Wiper**—Activates the camera lens window wiper. Click **Start** for one full wiper cycle.

### Caution

Before activating the wiper, make sure the lens window is wet. Using the wiper when the window is dry causes irreparable damage to the window coatings and voids the warranty. Use the wiper with [an optional wash kit](#), wait until it rains, or spray the lens window with a hose.



- **Washer device installed**—If you have installed an optional wash kit, click **On**. To apply changes to this setting, the camera needs to reboot.

When On is selected, the following washer controls are available:

- **Washer**

- **Start**—Turns the washer on for the amount of time specified for the wash spray duration below. If the camera's pan and tilt is not in the washer position, the camera moves to the washer position. If the washer position has not been defined, define one.
- **Finish**—Turns the washer off. If the camera's pan and tilt is in the washer position, the camera moves back to its previous position.

**Advanced Settings**

- **Washer Position**

- **PTZ controls**—Moves the camera. Set the washer position so that the washer sprays liquid over the camera lens window.
- **Go To**—Moves the camera to its washer position (if defined).
- **Set**—Sets the camera's current pan and tilt as its washer position.

- **Wash Spray Duration**—Specify the amount of time the washer turns on when you click **Start** under Washer, between 0-10 seconds.

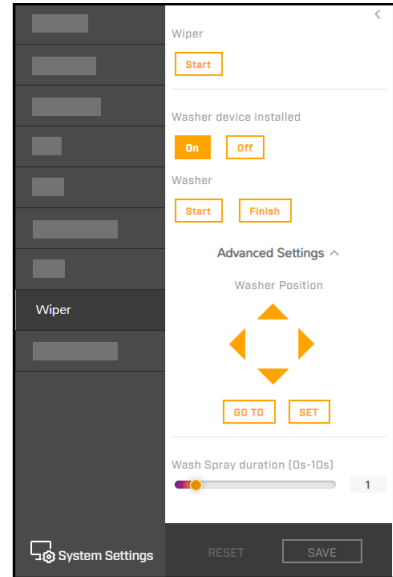

**Important**

If a wash kit is connected to the camera's Alarm-Out A1 and A2 pins on the 14-pin terminal block connector, these washer controls activate it through local output 1 (see [Input/Output \(I/O\) Page](#)). If another device is connected to the Alarm-Out A1 and A2 pins, the washer controls affect that device. If no device is connected to Alarm-Out A1 and A2, these controls only affect the camera's pan and tilt position (if a washer position is defined). For more information, see [Install and Test the Optional Wash Kit](#).

## 4.10 Georeference Page

Use the Georeference page to specify the camera's geographical location and mounting position.

For geographical location, specify:

- **Latitude**, in degrees North or South
- **Longitude**, in degrees East or West

**Tip**

To obtain the camera's latitude and longitude, use a map or a mobile GPS device.

For mounting position, specify:

- **Ground Altitude**, in meters above or below sea level

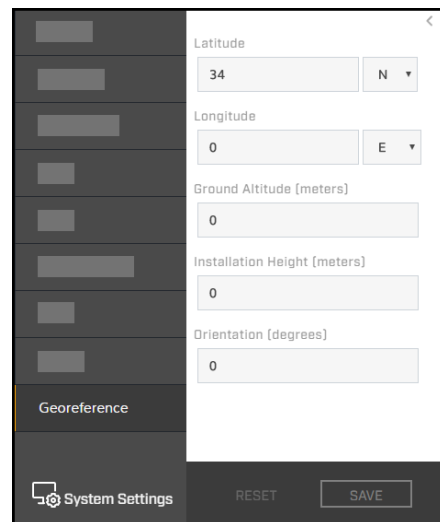

- **Installation Height**, in meters above the ground (must be greater than zero)
- **Orientation**: the installation angle of the “zero-pan” line of the camera, between 0-360 degrees from North

Preset positions are relative to the camera's orientation. Changing the orientation affects existing presets. If any presets have been defined, after changing the camera's orientation, go to the [PTZ Page](#) and redefine them.

After making any change on the Georeference page, click **Save** to save the changes.

The camera can report this georeference information via FLIR CGI/SDK or ONVIF, which:

- Allows the user or an application to:
  - Show the camera on a map
  - Show the direction the camera is facing (using the camera's field of view, which the camera also reports)
- Supports pan and tilt cueing. For example, the FLIR CGI protocol provides pan and tilt commands to point the camera at a specific geographic location (latitude/longitude).

## 5 Configuration

Users assigned the admin or expert role can click **System Settings** on the [View Settings Home Page](#) to configure:

- [Networking](#)
- [Date and time](#)
- [User accounts and passwords](#)
- [Audio parameters](#)
- [I/O devices](#)
- [Cybersecurity](#)
- [ONVIF interface](#)

In addition, users assigned the admin or expert role can access the [Firmware & Info page](#) to upgrade the camera's firmware, reset the camera to its factory defaults, reboot the camera, and configure other parameters.

### 5.1 Network Page

When a user assigned the expert or admin role clicks **System Settings**, the Network page appears.

The IP address mode can be set to DHCP (default) or Static.

Define the camera's hostname, which identifies the camera.

When the IP address mode is Static, specify:

- **IP**—The camera's IP address
- **Netmask**—The default value is 255.255.255.0
- **Gateway**

When the IP address mode is set to DHCP, if a DHCP server is not available on the network, the camera's default IP address is 192.168.0.250. For information about defining the camera's IP address using the DNA tool, see [Initial Configuration](#).

### Caution

After changing the camera's IP address, the PC you are using to access the camera's web page might no longer be on the same network as the camera and can no longer access the camera's web page. To access the camera web page again, change the PC's IP address to be on the same network as the camera.

When the IP address mode is DHCP, you can set the DNS Mode to DHCP or Static. When the IP address mode is Static, the DNS Mode is also Static.

When the DNS Mode is set to Static, specify:

- **Name Server 1**—The primary domain name server that translates host names into IP addresses
- **Name Server 2**—A secondary domain name server that backs up the primary DNS

You can also specify the:

- **MTU**—Maximum transmission unit, the largest amount of data that can be transferred in one physical frame on the network. For Ethernet, the MTU is 1500 bytes (the default setting). For PPPoE, the MTU is 1492. Valid values are 1000-1500.
- **Ethernet Speed**—When set to 100Mbps (default), the camera supports 100Mbps. When set to Auto, the camera supports 10/100/1000 Mbps.

## 5.2 Date & Time Page

Use the Date & Time page to configure the camera's date and time settings.

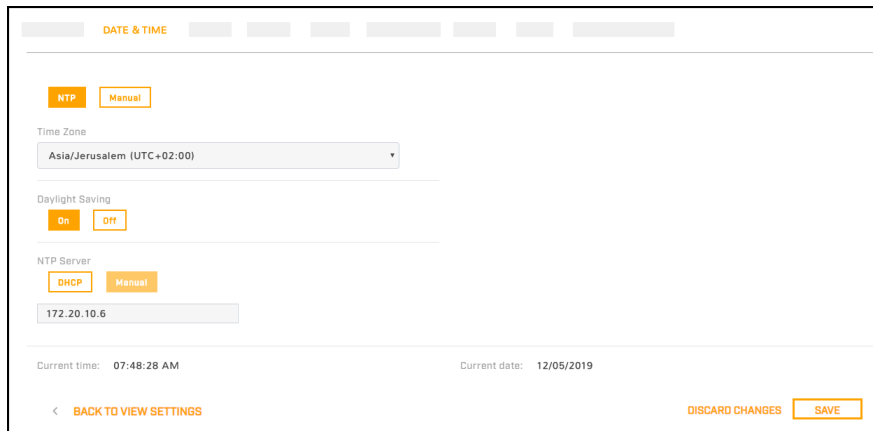

The camera can obtain the date, time, and time zone from an NTP server, or you can manually specify that information.

When set to Manual, you can copy the local PC's time or specify the hour, minute, second, and date.

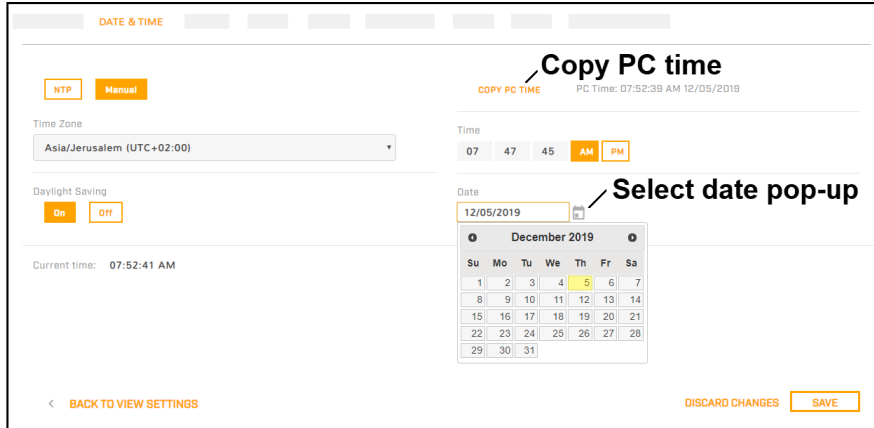

When set to NTP, you can specify whether the camera obtains the NTP server information from the DHCP server on the network, or manually enter the NTP server information.

After setting the date and time parameters, click **Save** at the bottom of the page. The camera requires a reboot, and a confirmation prompt appears.

### 5.3 Users Page

Only users assigned the admin role can add users and change or set all passwords.

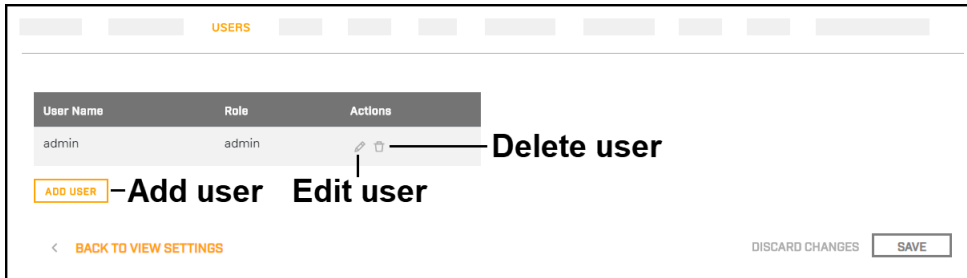

Users assigned the expert role only see the user currently logged in, and cannot add, edit, or delete a user.

To maintain security of the system, set up user names and passwords for each required login account.

Passwords must consist of at least 12 characters and include at least one uppercase letter, one lowercase letter, and one number. Passwords can include the following special characters: | @#~!\$&<>+\_-.,\*?= .

Assign one of the following roles, according to the level of access the user requires:

Role	Access
user	Can: <ul style="list-style-type: none"> <li>View live video</li> <li>Pan, tilt, and zoom the camera, including toggling between the emulated joystick and crosshairs control</li> <li>View the Help page</li> <li>Log out</li> </ul>

Role	Access
expert	Cannot manage users: <ul style="list-style-type: none"> <li>• Cannot add/edit/delete users</li> <li>• Cannot change passwords</li> </ul> Can access and use all other View Settings and System Settings pages, menus, controls, and settings
admin, including the default admin user	Can access and use all of the camera's web pages, including adding/editing/deleting users (but cannot delete the default admin user), and setting all passwords

All roles can access the camera's video streams, which require authentication. You can use the name and password for any of the camera's users.

*Add User*

Enter user

Enter password

Confirm password

Set role

Click Save

*Edit User*

Enter password

Confirm password

Set role

Click Save

*Delete User*

Click trash can icon

Click to confirm

## 5.4 Cloud Page

The cameras will support FLIR Cloud in future releases.

CLOUD

Cloud user

Cloud password

Device Name

ONBOARD
OFFBOARD

The camera has not been provisioned. Contact FLIR Support.

< [BACK TO VIEW SETTINGS](#)
DISCARD CHANGES SAVE

## 5.5 Audio Page

The Audio page provides configuration settings for the camera's audio input and output.

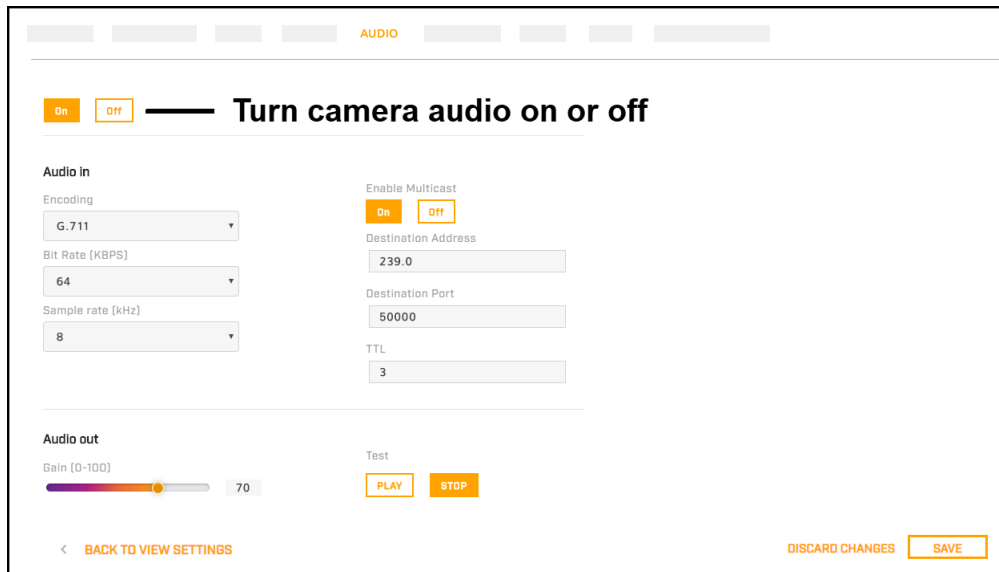

The On/Off buttons affect all audio input and output. Turning audio off immediately turns off all camera audio.

### Audio In

When audio is On, the following audio input settings appear:

- **Encoding**—G.711.
- **Bit Rate**—The camera supports an audio input bit rate of 64 kilobits per second (kbps).
- **Sampling Rate**—The camera supports a sample rate of 8 kHz.
- **Enable Multicast**—Can be set to On (default) or Off. When On, specify the destination address and port, and the time-to-live (TTL).

### Audio Out

When audio is On, you can adjust the audio line output gain from 0-100 percent. The default gain is 80 percent.



#### Tips

- Test whether the camera's audio output is functioning properly by clicking **Play**.
- If you are monitoring the audio IP output with a video stream and change any of the audio configuration settings except gain, restart the stream. For example, if you are monitoring a video stream and turn audio on, you need to restart the stream to hear the audio with the stream.

## 5.6 I/O Devices Page

The I/O Devices page provides configuration settings for external I/O connections and the device managing those connections with the camera.

I/O DEVICES

Device IP Address: 127.0.0.1    Port: 502

Input base address: 0    Output base address: 0

I/O pins

Number of input pins: 3    Number of output pins: 3

\*Choose 0 to disable the auto reset for the output pin (0-600 sec) Refresh

I/O	Type	State	Idle State	Alarm Auto Ack	Enabled	Reset Interval (seconds)*
0	Input	Off	Open	NO	YES	
1	Input	Off	Open	NO	YES	
2	Input	Off	Open	NO	YES	
3	Output	Off	Open	NO	YES	0
4	Output	Off	Open	NO	YES	0
5	Output	Off	Open	NO	YES	0

[BACK TO VIEW SETTINGS](#)    [DISCARD CHANGES](#)    [SAVE](#)

The following settings for the device managing the external I/O connections are available:

- **Enabled or Disabled**
- **Device IP address and port**
- **Input and output base addresses**

You can define the number of input and output pins the device manages.

The following information appears for each pin:

- **I/O pin number**
- **Type**—Input or Output
- **State**—the pin's current state: Open or Closed

For each pin, you can define the following:

- **Idle State**—Open or Closed
- **Alarm Auto Ack**—Yes or No
- **Enabled**—Yes or No
- **Reset Interval (for output pins only)**—between 0-600 seconds; specifying 0 seconds disables the auto reset

### Related Operation and Configuration Information

For information about changing the current state of the input and output pins, see [I/O Page](#).

For more information about how to configure the device managing the external I/O connections, refer to the device's documentation.



## 5.7 Cyber Page

The Cyber page provides security configuration settings for:

- [Certificates](#)
- [IEEE 802.1X-compliant communication](#)
- [Transport Layer Security \(TLS\) and secure HTTP \(HTTPS\) communication](#)
- [Other cybersecurity services](#)

Changes to the security configuration settings on the Cyber page do not immediately take effect. To apply changes, click **Save** and then reboot the camera.

The screenshot shows the 'CYBER' configuration page. On the left sidebar, 'Certificates' is selected. The main content area is titled 'Certification area' and shows 'TLS/HTTPS' and '802.1x' selected. There are two radio buttons: 'Self-Signed' (selected) and 'Upload Certificate'. Below these are several input fields: Country Code, Province Name, City Name, Common Name, Organization Name, Organization Unit Name, Email Address, and Expiration Time (months). A 'CREATE CERTIFICATE' button is located below the input fields. At the bottom left, there is a '< BACK TO VIEW SETTINGS' link. At the bottom right, there are 'DISCARD CHANGES' and 'SAVE' buttons.

### 5.7.1 Certificates

Before you can enable TLS/HTTPS or 802.1X, you need to generate or upload a valid certificate. You can:

- Use the camera's web page to generate a self-signed certificate.
- Upload a self-signed certificate.
- Upload a certificate signed by a third-party.

Certificates and keys must be in PEM format. Common file extensions for TLS files in PEM format are:

- **For certificate and public key files:** \*.crt, \*.cer, \*.cert, \*.pem
- **For private key files:** \*.key

From the Certificates section of the Cyber page, you can download certificates and keys previously uploaded to or generated by the camera. If the certificate saved on the camera is self-signed, you can download the private and public key files. If the certificate was signed by a third-party CA, you can download the CA Certificate and the private and public key files.

**To generate and install a self-signed certificate for TLS/HTTPS:**



1. In the Certificates section and Certification area, select **TLS/HTTPS** and **Self-Signed**.
2. Enter information such as country code, city name, and organization name.
3. Click **Create Certificate**.
4. Allow 15 seconds for the camera to generate the certificate, at which point a confirmation appears.

**To upload a self-signed or third-party CA signed certificate for TLS/HTTPS or for 802.1X:**

1. In the Certification area, click **TLS/HTTPS** and then select **Upload Certificates**, or click **802.1x**.

To upload a certificate for TLS/HTTPS

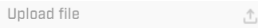
To upload a certificate for 802.1X

2. If you are uploading a self-signed certificate, under **Public Key** and then under **Private Key**:
  - a. Click .
  - b. Select the appropriate key file.
  - c. Click .

If you are uploading a third-party CA signed certificate, select and upload the Public Key, Private Key, and CA Certificate.

3. Verify that the camera certificate files are valid and make sure *Certificates are OK* appears under the certificate information, under Download certificate.



Note that you can download keys and certificates from the camera.

Changes in the Certificates section do not immediately take effect. To apply changes, click **Save** and then reboot the camera.

**5.7.2 802.1x**

Enable or disable IEEE 802.1X-compliant TLS communication.

Provide an Identity and Private Key Password.

Changing these settings does not immediately take effect. To apply a change to these settings, click **Save** and then reboot the camera.

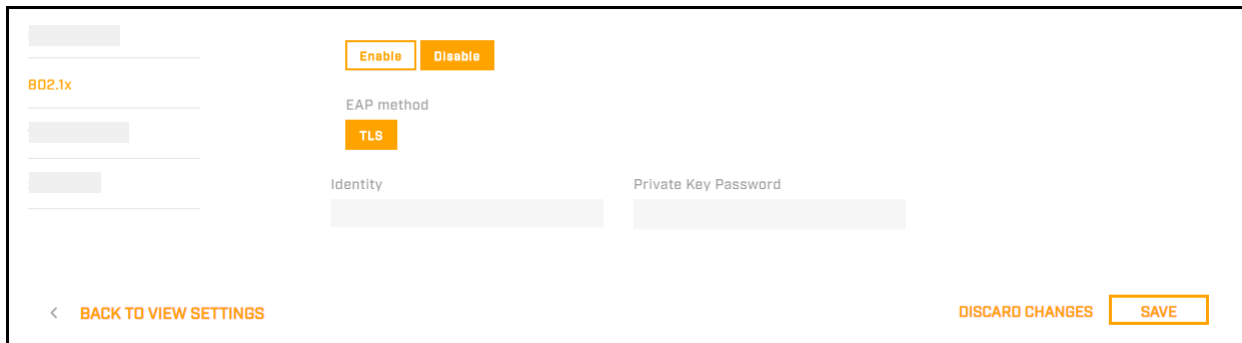

### 5.7.3 TLS/HTTPS

Enable or disable camera control using Transport Layer Security (TLS)/secure HTTP (HTTPS).

Enable or disable HTTPS redirect.

Changes to these settings do not immediately take effect. To apply the changes, click **Save** and then reboot the camera.

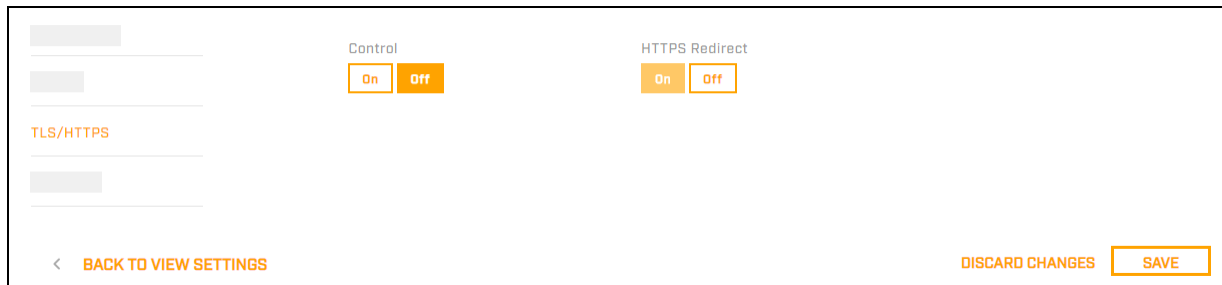

### 5.7.4 Services

Enable or disable digest authentication for the FLIR CGI control interface. The default setting is **On** (enabled).

#### Firewall Settings

For enhanced security, the camera has a firewall that you can enable by clicking **On**. By default, when you enable the firewall, the following services are set to **Allow**, which means they remain enabled and their default ports remain open:

- RTSP
- UPNP
- Nexus Discovery
- Nexus SDK
- ICMP

To disable a service and its default port, click **Block**.



**Caution**

Disabling services and ports can affect product functionality.

Changes to Services settings do not immediately take effect. To apply changes to these settings, click **Save** and then reboot the camera.

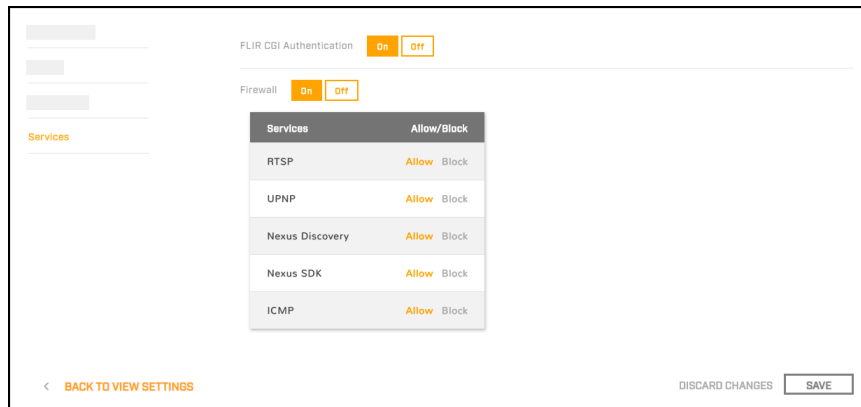

## 5.8 ONVIF Page

The ONVIF page provides settings for auxiliary commands and for output actions.

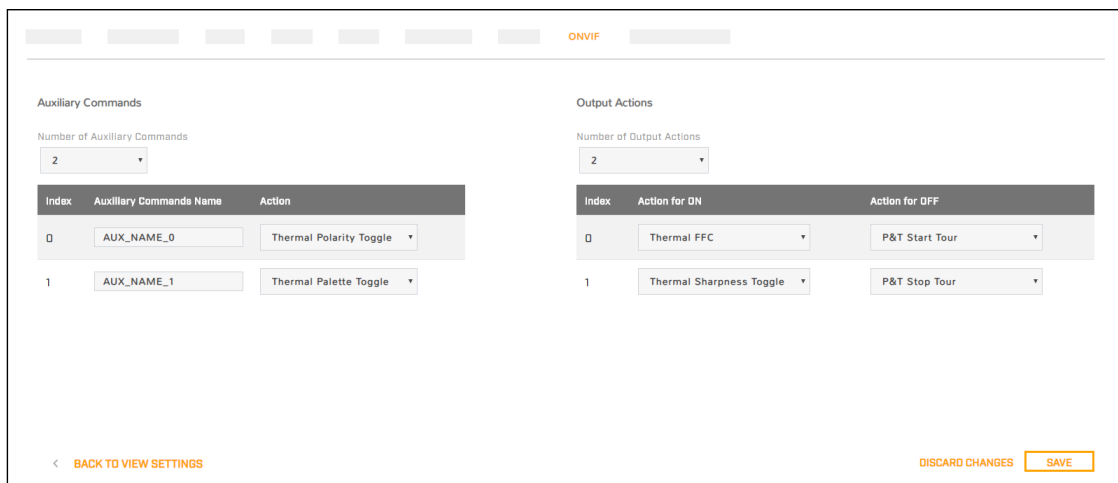

### To configure the ONVIF interface:

1. Select the number of auxiliary commands (up to seven) and the number of output actions (also up to seven).
2. For each auxiliary command action, specify the ONVIF command name.
3. For each auxiliary command action, and separately for each ON and OFF output action, select one of the following:
  - **None**
  - **P&T Start Tour**—If a tour is defined on [PTZ Page](#), initiates a tour of pan and tilt preset positions.
  - **P&T Stop Tour**—If a tour is defined on [PTZ Page](#), stops the tour of pan and tilt preset positions.

## 5.9 Firmware & Info Page

On the Firmware & Info page, you can:

- Specify a unique name for the camera
- Upgrade the camera's firmware
- Reset the camera to its factory defaults
- Reboot the camera
- Define a log level and download system information

### Name

Specify a unique, friendly name for the camera, using only alphanumeric characters. The default name for the camera is the camera model followed by the camera's serial number.

### To upgrade the camera's firmware:

1. Make sure the camera has been recently rebooted.
2. Under Upgrade version, click **Find file**.
3. On your computer or network, browse to and select the firmware file.



**Caution**  
Only upgrade to firmware developed for Quasar CP-6408 cameras.

4. Click **Upgrade**.

The camera uploads and installs the firmware, which takes a minute or two. After installing firmware, the camera requires a reboot. When prompted, confirm rebooting the camera.

### Factory Defaults

Click **Full Reset** to return the camera its original factory configuration.

Click **Partial Reset** to keep the current settings on the Network page and return all other settings to their factory defaults.

Click **Reboot** to cause the camera to power cycle and reinstall configuration files.



### Tip

You can also return the camera to its original factory configuration by pressing the camera's physical Default button for at least 20 seconds; for example, if you are unable to access the camera via its web page or other communication method. The Default button is located on the camera's connector panel.

### Support System Info

Set the logging detail up to four levels; higher log levels increase the size of the log file.

Click **Download** to retrieve the camera's log files.

---

## 6 Maintenance and Troubleshooting Tips

If help is needed during installation, operation, or configuration, contact the local FLIR representative, or visit the FLIR Support Center at: <https://support.flir.com/>.

### 6.1 Cleaning

Great care should be used with your camera's optics. They are delicate and can be damaged by improper cleaning. The camera's lens window is designed for a harsh outdoor environment and is coated for durability and anti-reflection. However, it can require occasional cleaning. If you are not using an optional wash kit (with the CP-6408-31-I camera), FLIR suggests that you clean the lens window when you notice image quality degradation or excessive contaminant build-up on it.



#### Note

Do not disturb or move camera during cleaning.

Rinse the camera housing and optics with low pressure fresh water to remove any salt deposits and to keep it clean. If the front window of the camera gets water spots, wipe it with a clean soft cotton cloth dampened with fresh water.

Do not use abrasive materials, such as paper or scrub brushes, as this can damage the lens window by scratching it. Only wipe the lens window clean when you can visually see contamination on the surface.

Use the following procedure and solvents, as required:

- Acetone – removal of grease
  - Ethanol – removal of fingerprints and other contaminants
  - Alcohol – final cleaning (before use)
1. Immerse lens tissue (optical grade) in Alcohol, Acetone, or Ethanol (reagent grade).
  2. With a new tissue each time, wipe the lens window in an “S” motion (so that you do not wipe any area more than once).
  3. Repeat until the lens window is clean. Use a new tissue each time.

### 6.2 Troubleshooting

#### No Video

If the camera will not produce an image, check the connections at the camera and at the display. If the connectors appear to be properly connected but the camera still does not produce an image, ensure that power has been properly applied to the camera and the circuit breaker is set properly. If a fuse was used, be sure the fuse is not blown.

If the camera still does not produce an image, contact the FLIR dealer or reseller who provided the camera, or contact FLIR directly.

#### Unable to Communicate over Ethernet

First check to ensure the physical connections are intact and that the camera is powered on and providing analog video to the monitor (CP-6408-21-I only).

By default the camera will broadcast a discovery packet two times per second. Use the FLIR Discovery Network Assistant (DNA) tool or a packet sniffer utility such as Wireshark and confirm the packets are being received by the PC from the camera.

### Unable to View Video Stream

If the video stream from the camera is not displayed, it could be that the packets are blocked by the firewall, or there could be a conflict with video codecs that are installed for other video programs.

When displaying video with a VMS for the first time, the Windows Personal Firewall may ask for permission to allow the video player to communicate on the network. Select the check boxes (domain/private/public) that are appropriate for the network.

If necessary, test to make sure the video from the camera can be viewed by a generic video player such as VLC media player (<http://www.videolan.org/vlc/>). To view the video stream, specify RTSP port 554 and the appropriate stream name. For example, using the camera's default IP address when there is no DHCP server on the network (192.168.0.250):

**rtsp://192.168.0.250:554/stream1** for Visible 1

**rtsp://192.168.0.250:554/stream2** for Visible 2

Accessing any of the camera's video streams requires authentication. You can use the name and password for any of the camera's users. See [Users Page](#).

Refer to [Network Options](#) for additional information on RTP settings and stream names.





---

FLIR Systems, Inc.  
6769 Hollister Ave  
Goleta, CA 93117  
USA

Corporate Headquarters  
FLIR Systems, Inc.  
27700 SW Parkway Ave.  
Wilsonville, OR 97070  
USA

Support:  
<https://support.flir.com/>

Document:  
CP-6408 Range Installation and User Guide  
Revision: 130  
Date: May 2021